

DANCOVER[®]

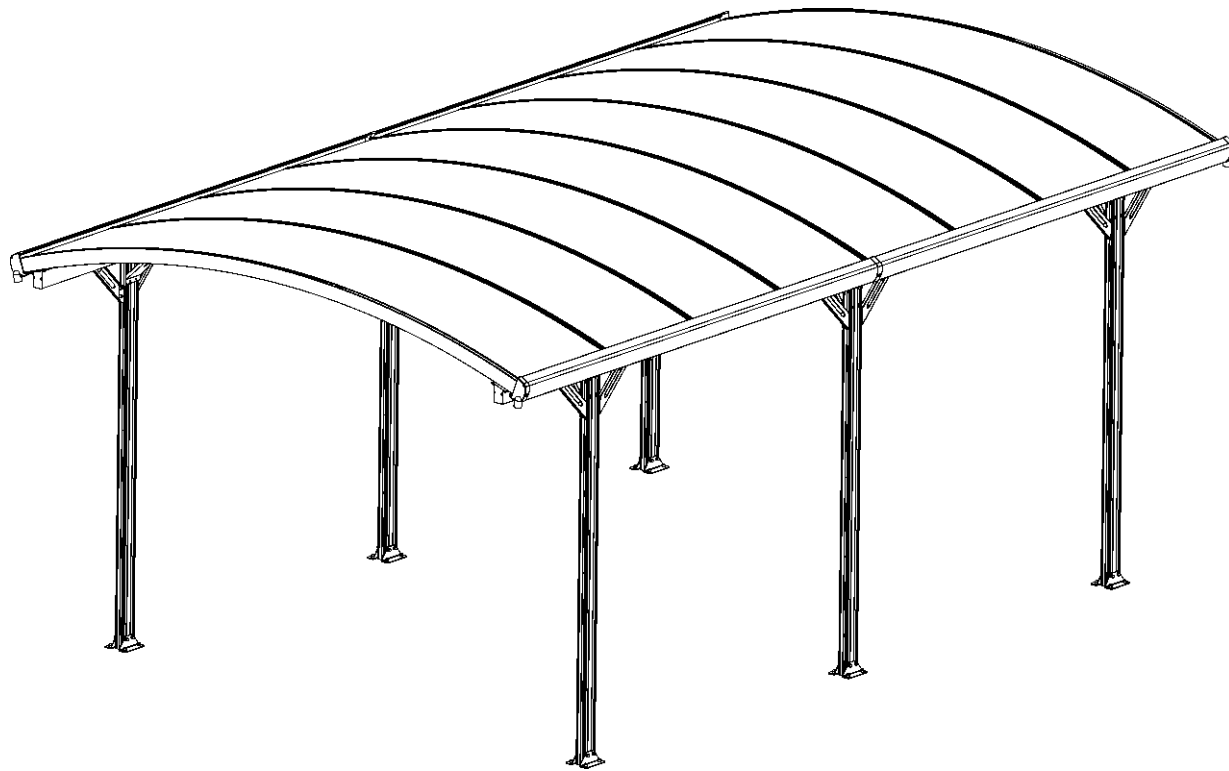

Manual
for
Carport Boston
3,03x5,05x2,22m

Carport Assembly Instructions



Product Size(LxWxH): 505x303x188/222cm

IMPORTANT

Please read the instructions carefully before you start to assemble this carport.

Please ensure that you find all parts in the carton in the correct type and quantity as mentioned in the illustrated content list.

Please carry out the steps in the order set out in the instructions.

Tighten all screws and parts, after completed the assembly of the polycarbonate panels.

Keep the instructions in a safe place for future reference.

SAFETY ADVICE

- We strongly recommend the product to be assembled by at least two people.
- Do not attempt to assemble the carport in windy or wet conditions.
- Do not position your carport in an area exposed to excessive wind.
- Identify any possible hazards including underground and overhead power cables and underground water pipes etc.
- Always wear gloves, safety goggles, long sleeves and shoes when assembling or performing any maintenance on your product.
- Some parts may have sharp edges. Please be careful when handling components.
- When using a stepladder or power tools, make sure you follow the manufacturer's safety advice.
- Dispose of all plastic bags safety-keep them out of reach of children.
- Keep children away from the assembly area.
- Do not attempt to assembly the carport if you are tired, have taken drugs or alcohol or if you are prone to dizzy spells.
- Do not climb or stand on the roof, to avoid falling down.
- Heavy snow load on roof will damage the product and making it unsafe to stand below or nearby. Please clean up the roof snow in time.









CLEANING & MAINTENANCE

- When your carport needs cleaning, use a mild detergent solution and rinse with clean water.
- Do not use acetone, abrasive cleaners or other special detergents to clean the panels.
- Keep roof and gutter clear of snow, dirt and leaves.
- Hot items such as recently used grills, blowtorches etc, must not be stores in the carport.
- Heavy articles should not be leaned against the poles.
- Do not hang or lay on the profiles.
- Put small component parts (screws etc) in a box, so they will not missing.
Some parts maybe surplus after assembly, it is recommended to keep them in a safe place for future use.

BEFORE ASSEMBLY





- Choose the site carefully before assembly, an unobstructed place, sheltered from strong winds is the best.
- Site surface needs to be flat and leveled.
- This carport should be assembled on a solid foundation (such as concrete or asphalt) and anchored to the ground.
- Make sure the wall you selected is strong enough for installation, a brick concrete structures is the best choice.
- Sort the parts and check according to the contents parts list.
- Please consult your local authorities if any permits are required prior to constructing the product.



Part List









PART	#	mm	Qty.
	J03L		2
	J03R		2
	J04		2
	J06-1		4
	J07		2
	Q01	M6*10	195
	Q02	M8*14	24
	P01	Ø8*80	24

PART	#	mm	Qty.
	S01	M6*12	172
	M01	M6	115
	Z01	Ø4*6	8
	Z02	Ø4*16	18
	Z03	Ø4*8	12
	N01	Ø6*Ø12*1	29
	N02	Ø6*Ø18*1	2
	N03	Ø5*Ø15*1	2

PART	#	mm	Qty.
	Y	3000*612	8

PART	#	mm	Qty.
	W02		12
	W03	Ø3.5*100	4
	W05	200*20*5	3
	W15	316*57*35	12
	W16B	392*104*33	6



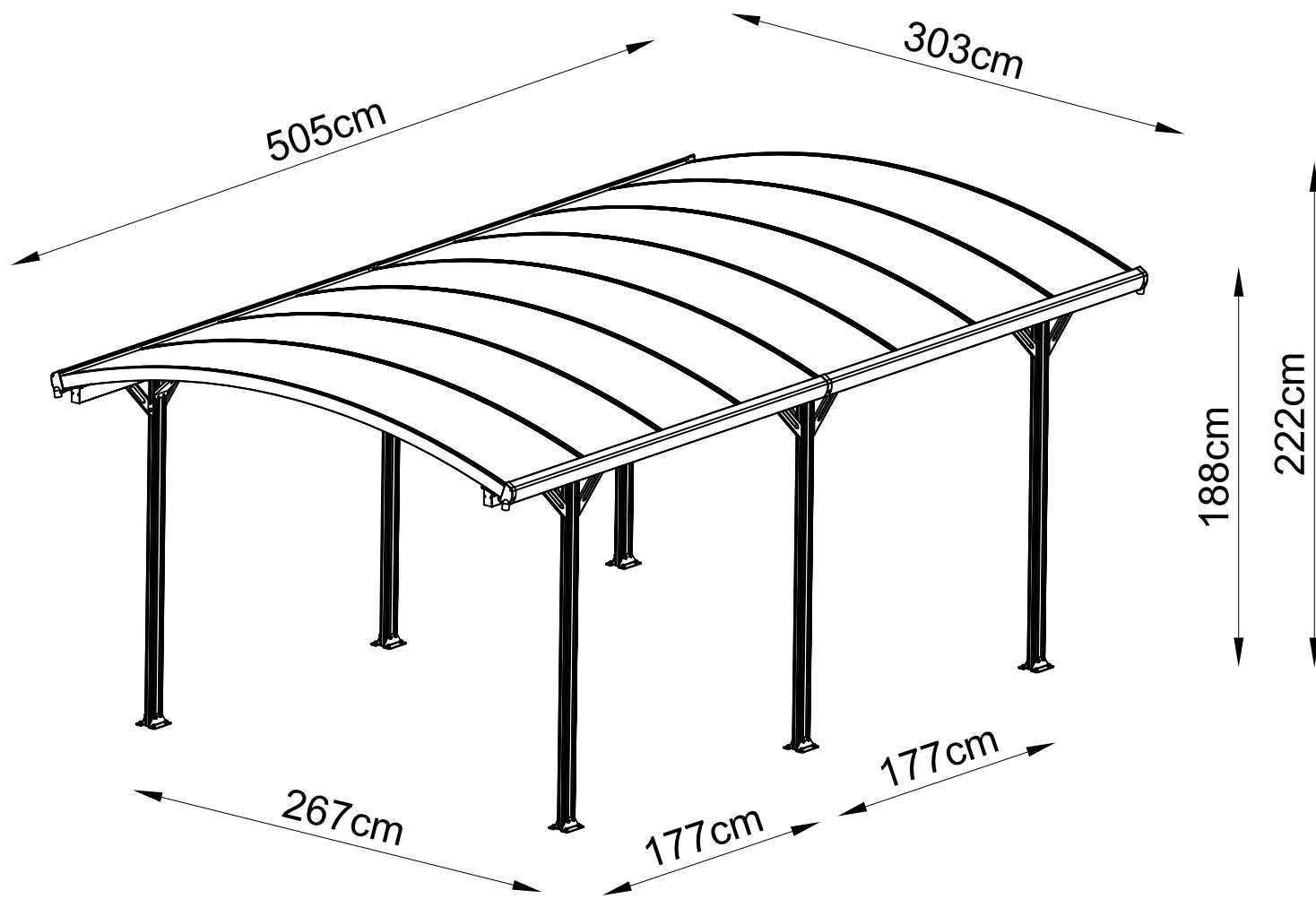

TOOL			
	T01		1
	T02		1
	T03		1

PART	#	mm	Qty.
	L01	2932	7
	L02	2932	2
	L06L	2525	2
	L06R	2525	2
	L07L	2507	2
	L07R	2507	2
	L08A	1873	6
	L10L	2525	2
	L10R	2525	2
	L13A	2507	2
	L13B	100	2
	L14	2507	2

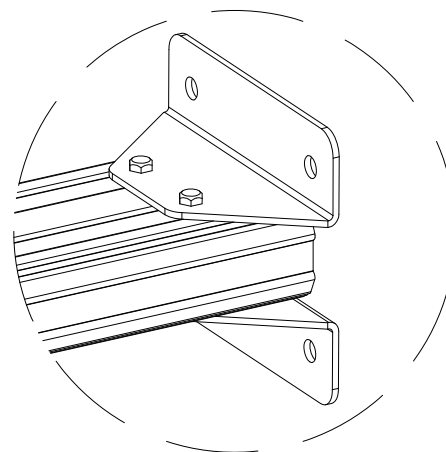
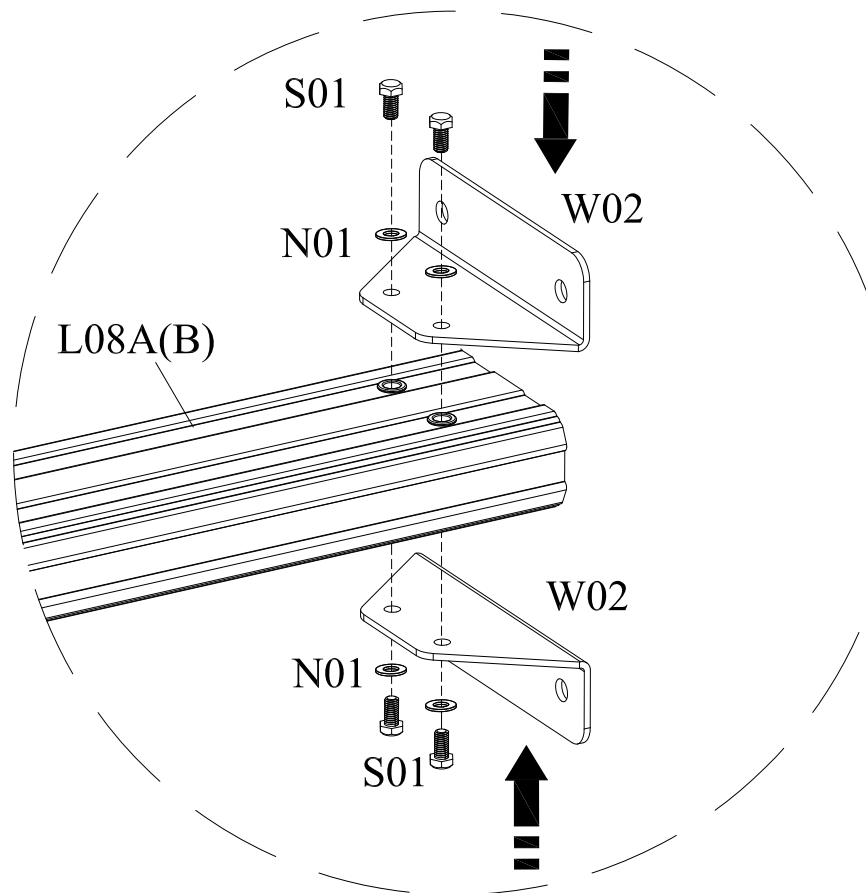
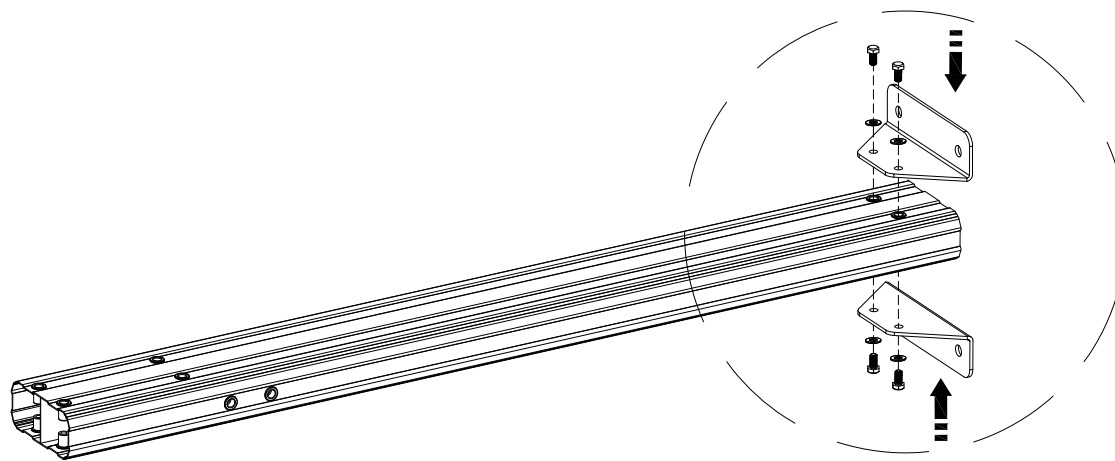



Make sure there is enough space to assemble the carport.

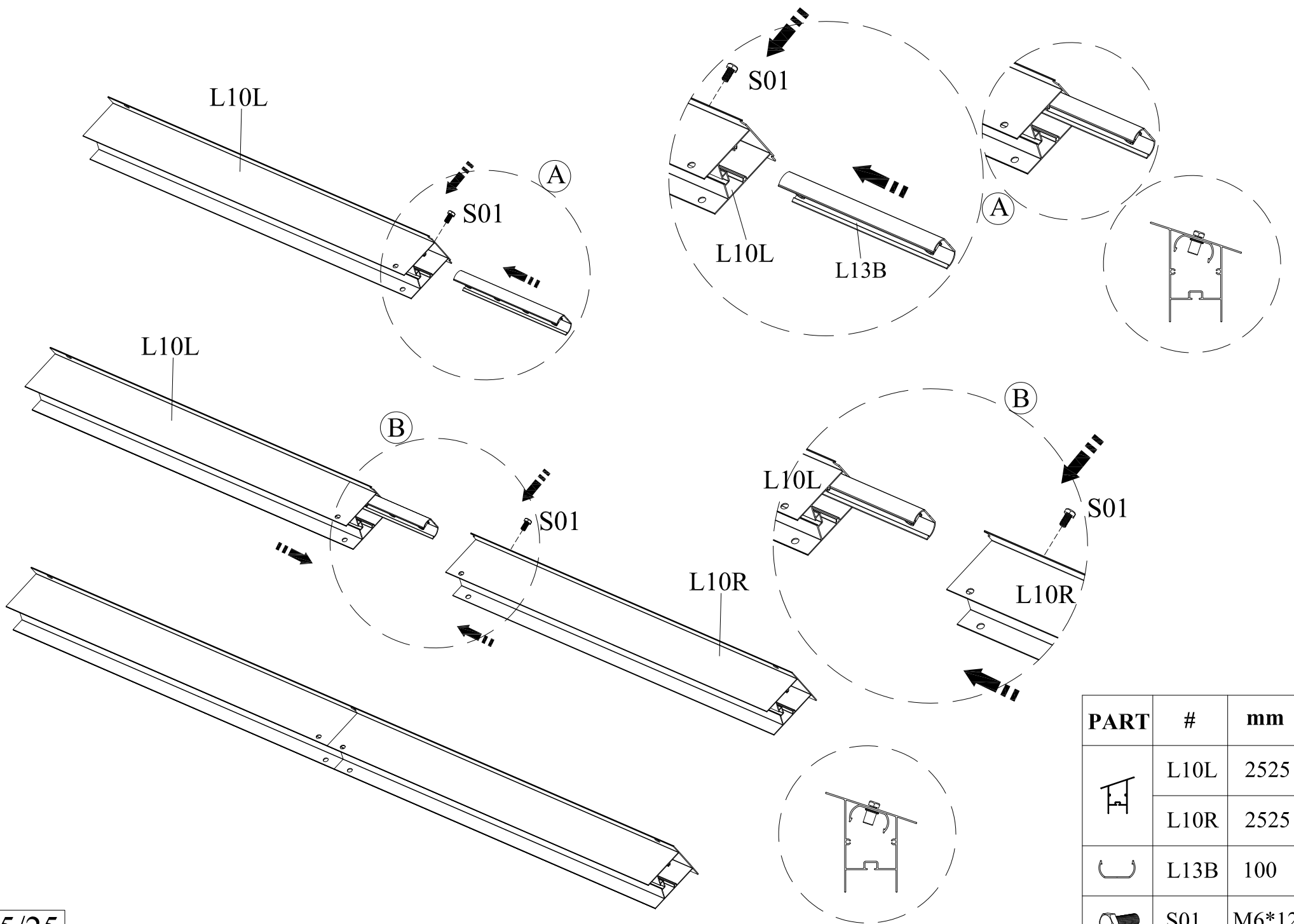

PART	#	mm	Qty.
	L08A	1873	6
	W02		12
	S01	M6*12	24
	N01	Ø6*Ø12*1	24



PART	#	mm	Qty.
	L10L	2525	2
	L10R	2525	2
	L13B	100	2
	S01	M6*12	4

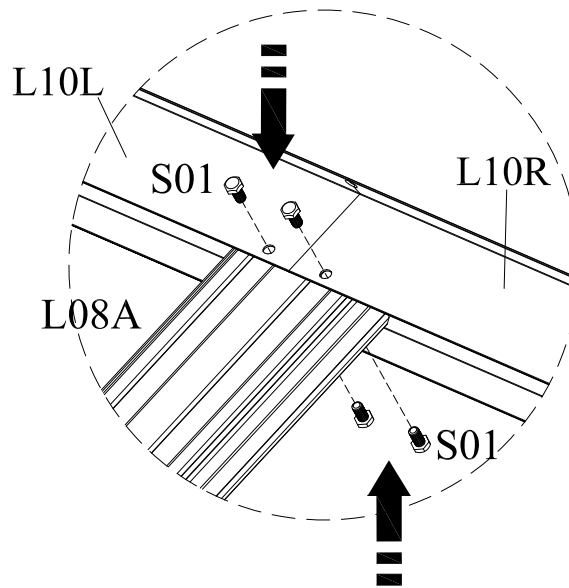
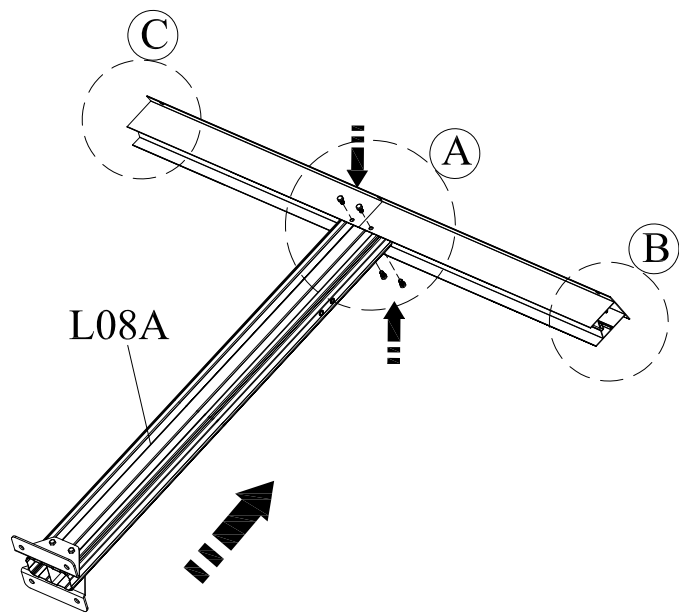

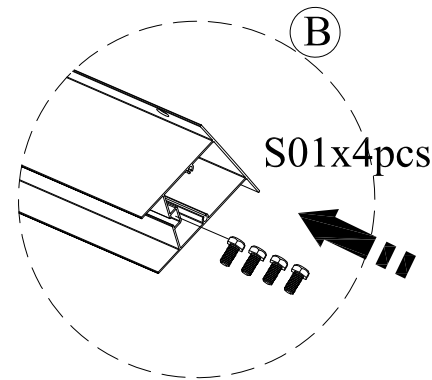
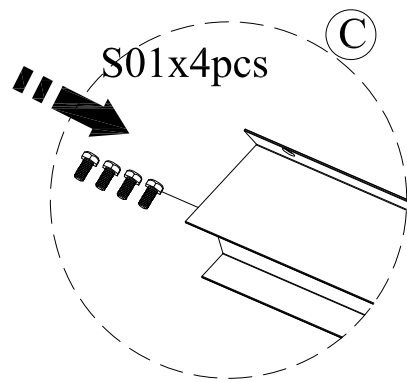
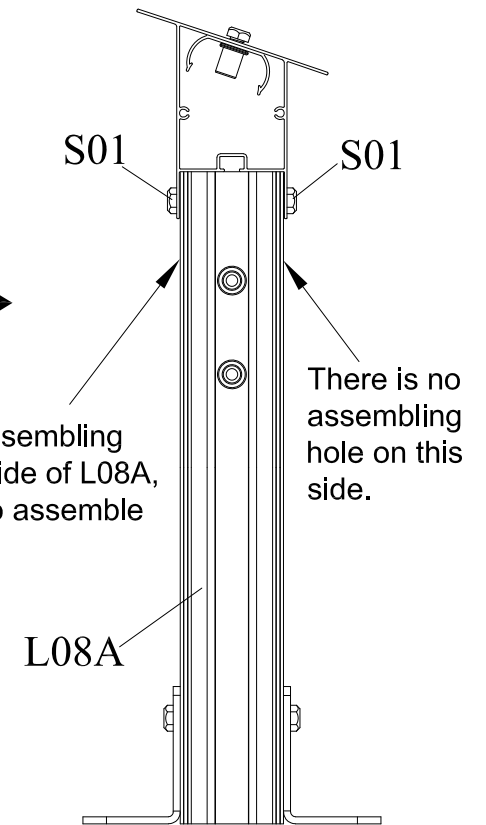

There are 2 assembling holes on this side of L08A, see page 13 to assemble W16B.



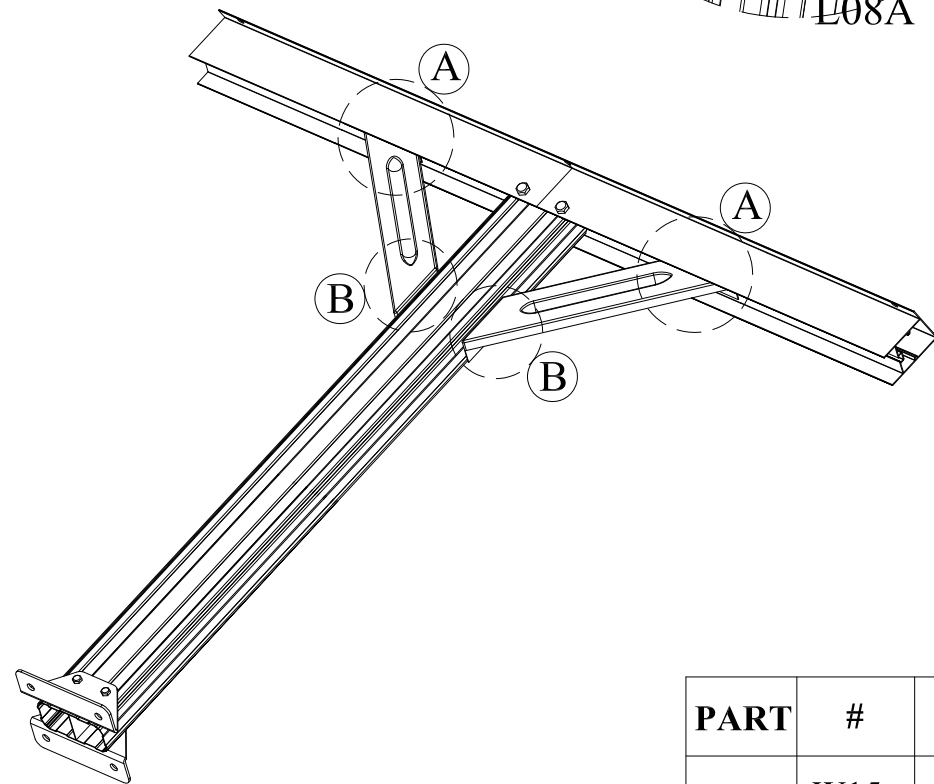
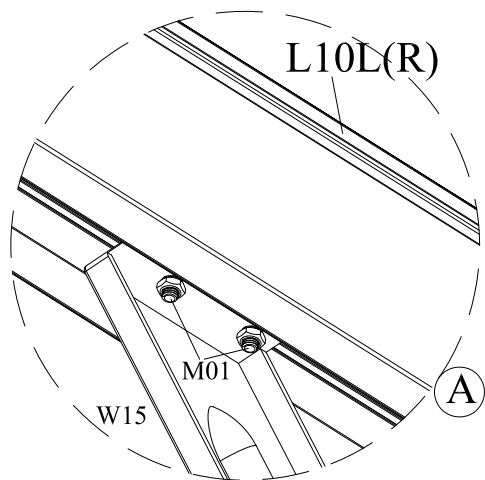
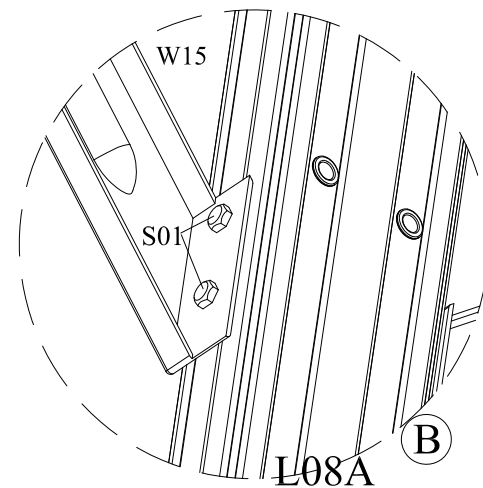
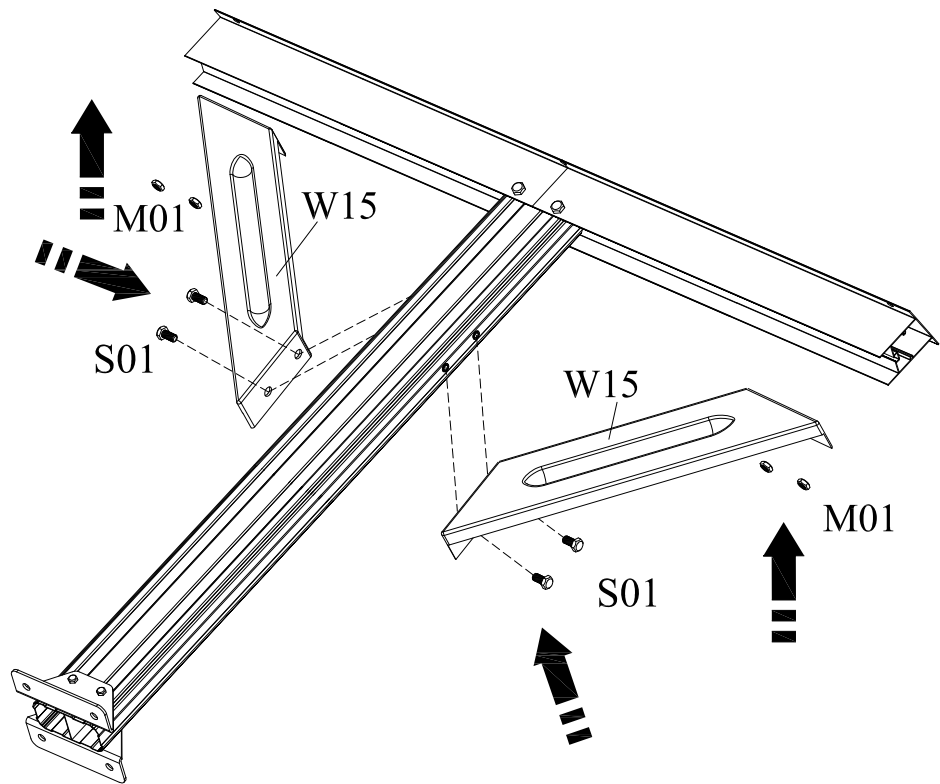

PART	#	mm	Qty.
	S01	M6*12	24



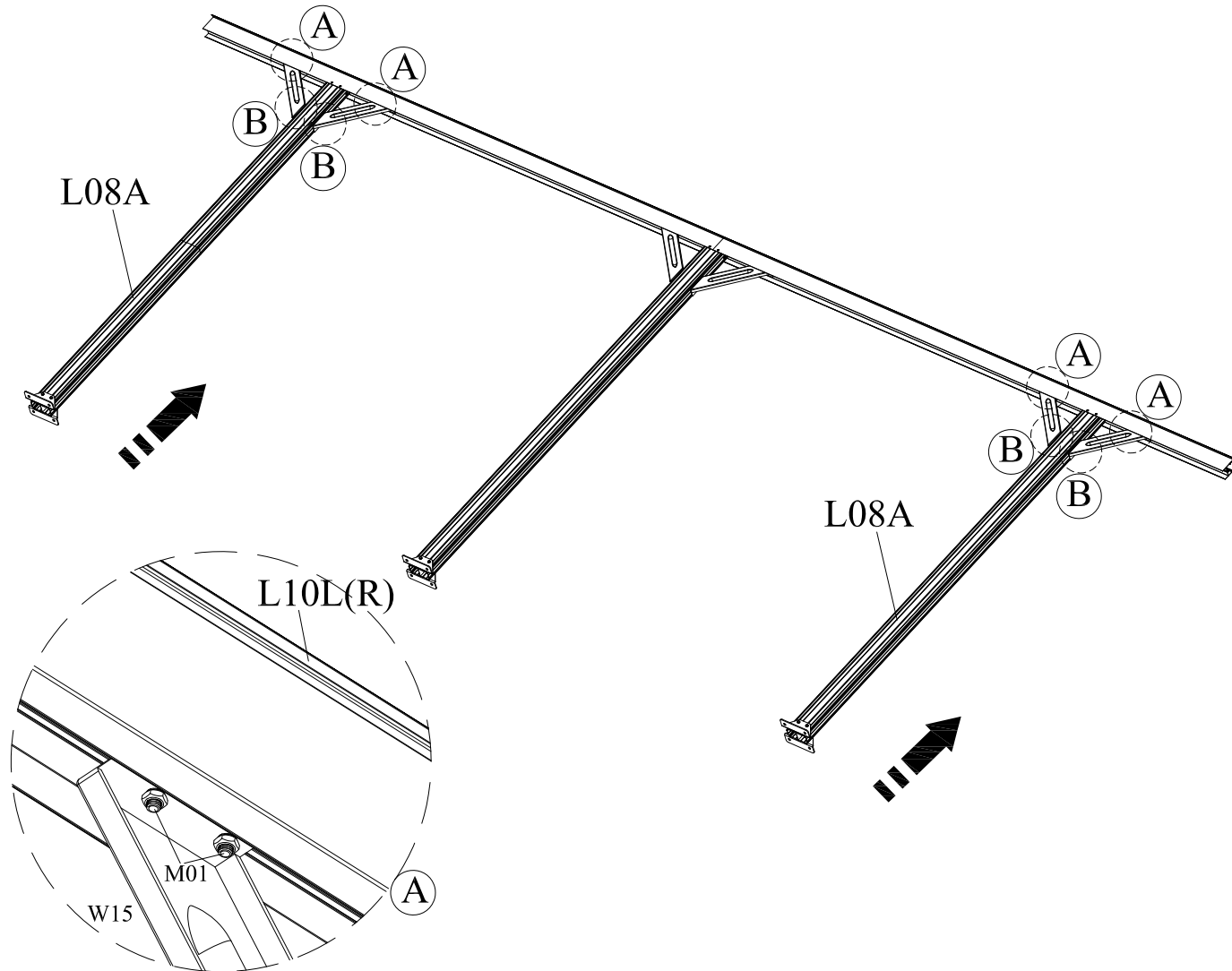

PART	#	mm	Qty.
	W15	316*57*35	4
	S01	M6*12	8
	M01	M6	8

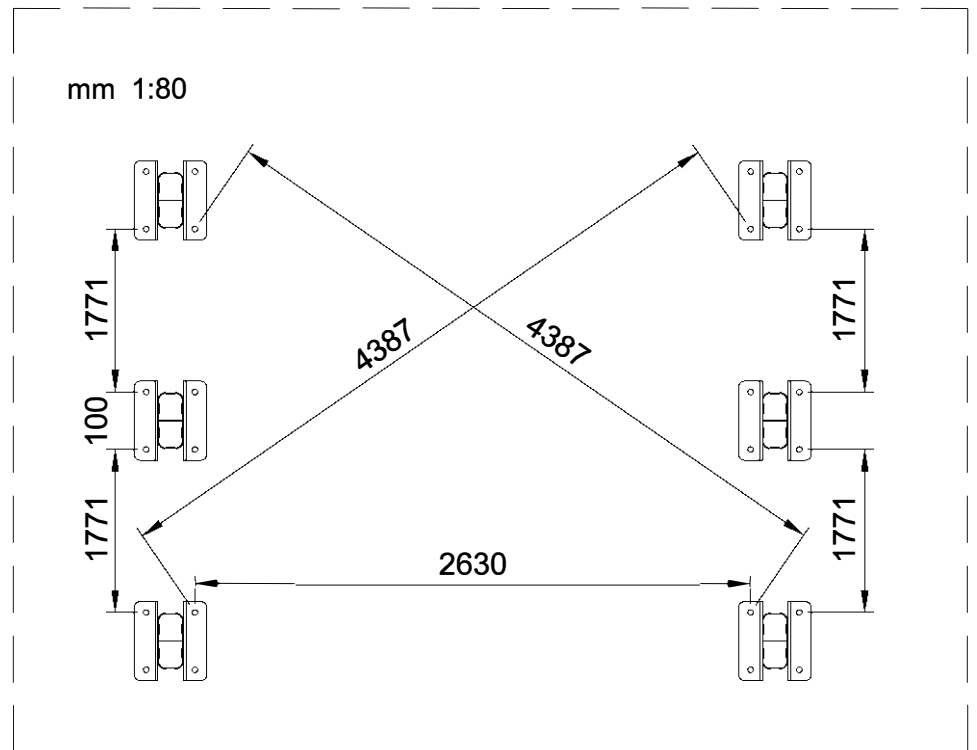
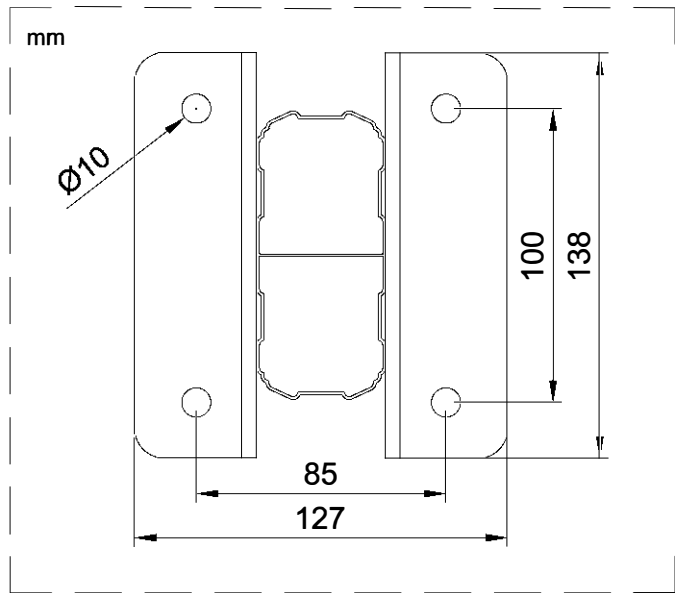
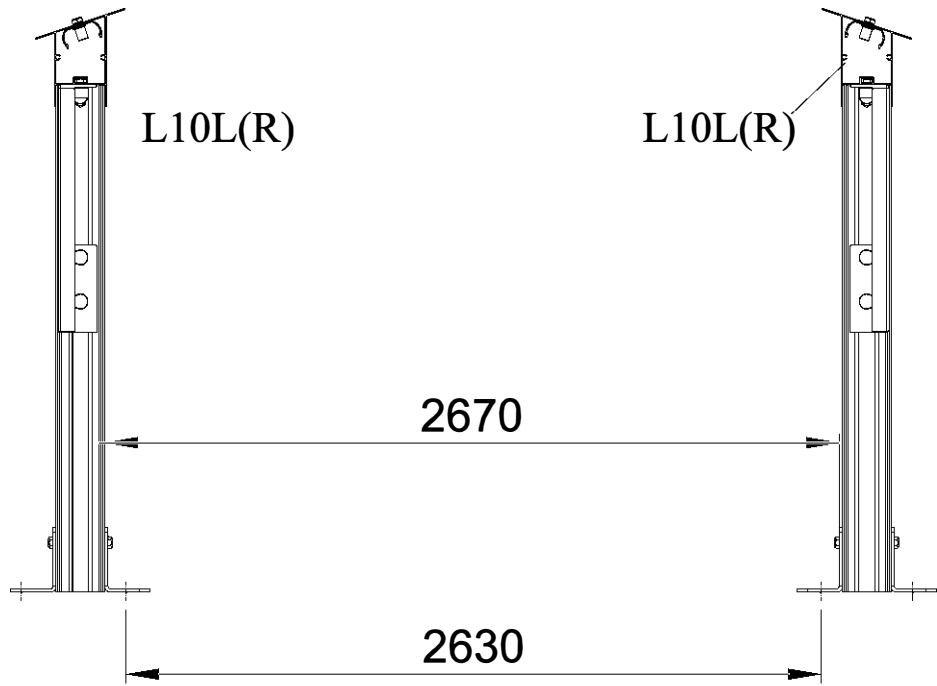

PART	#	mm	Qty.
	W15	316*57*35	8
	S01	M6*12	16
	M01	M6	16

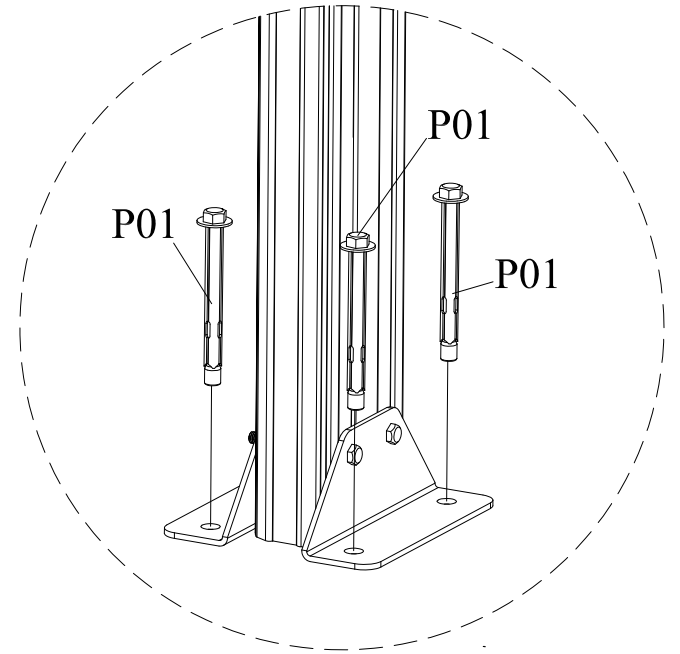
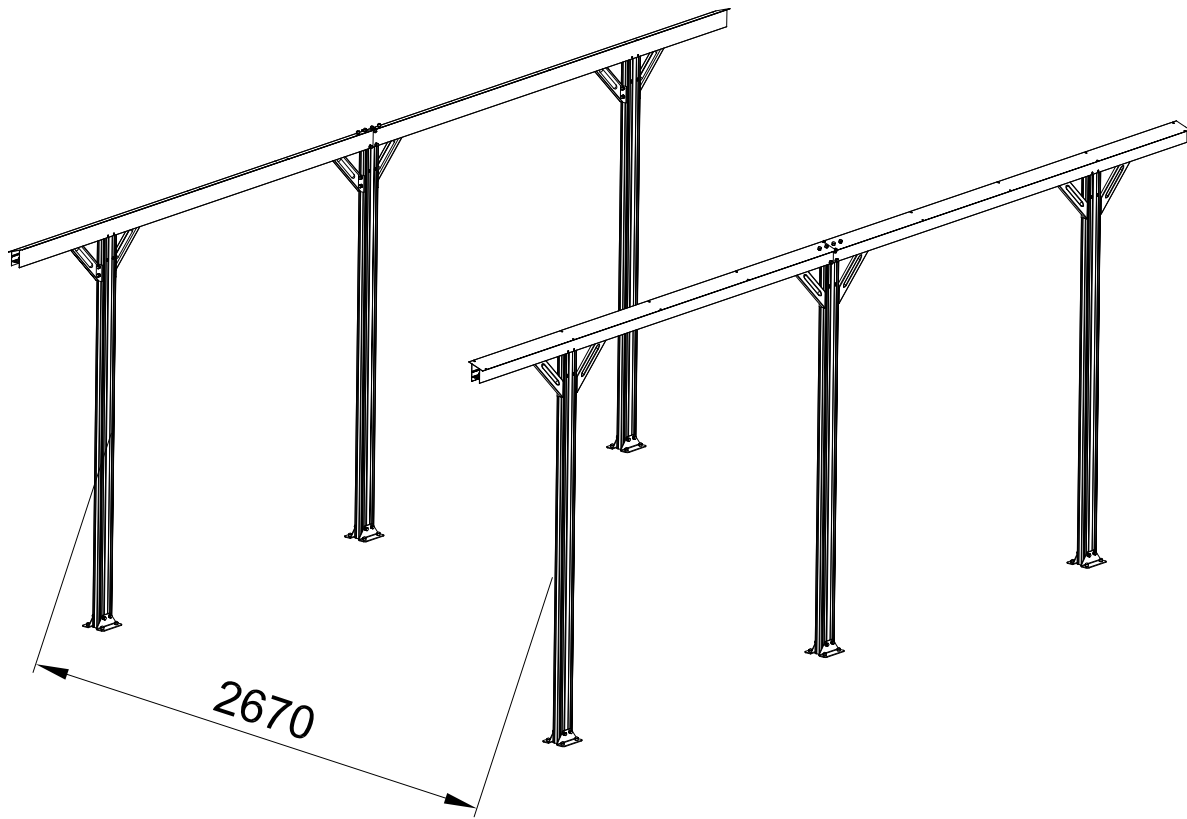





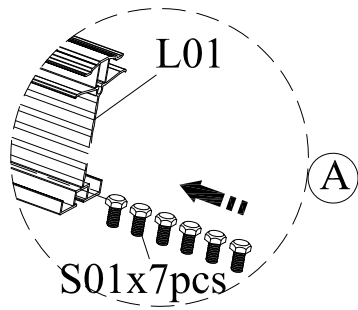

PART	#	mm	Qty.
	P01	Ø8*80	24

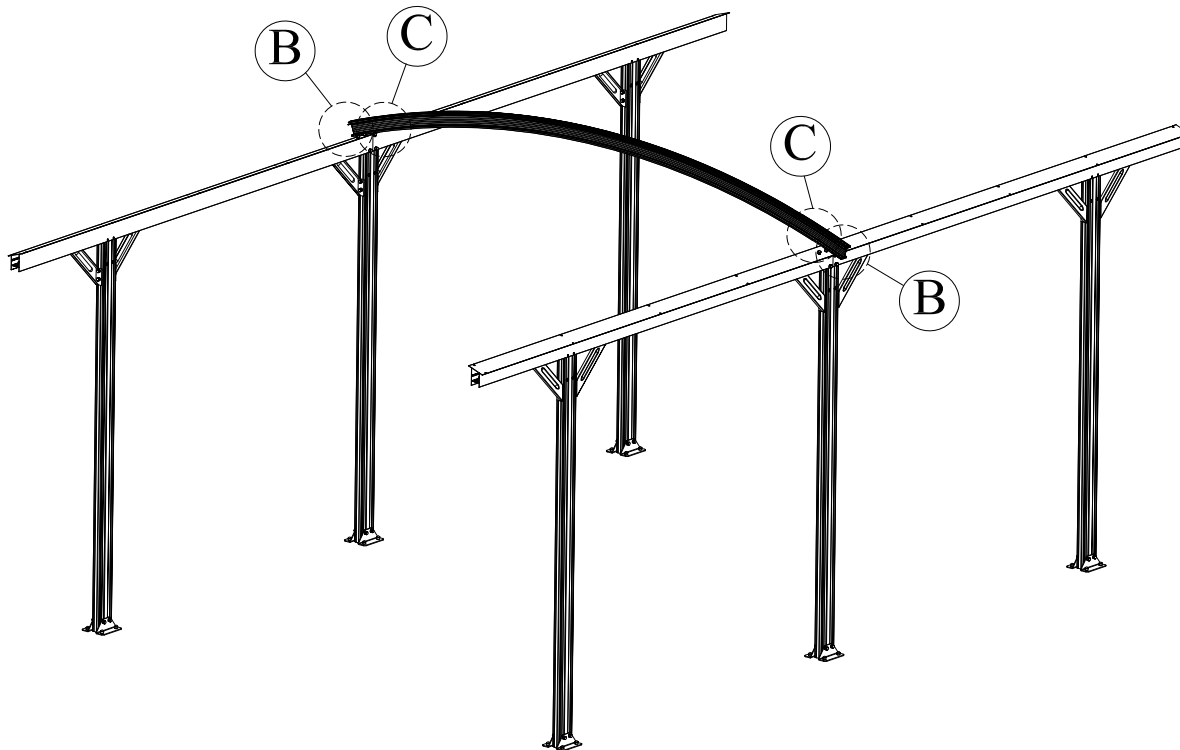
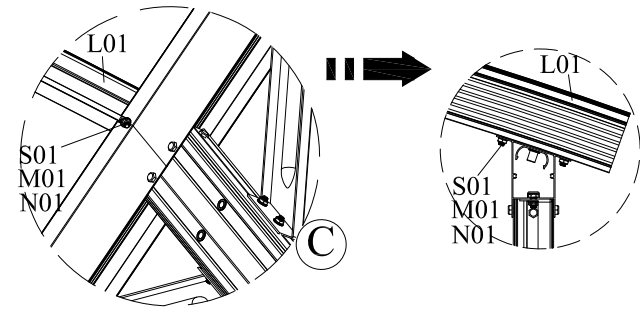
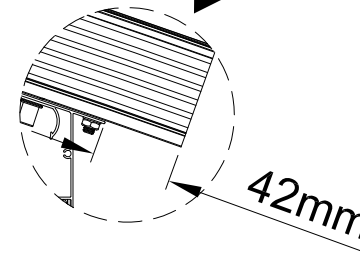
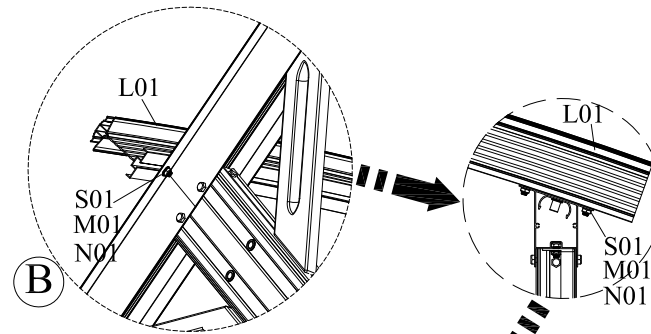

Pre-sliding bolt S01 x 7
before assembling L01, they
will be used for assemble
L10L, L10R, W16B, L13A in
following steps.



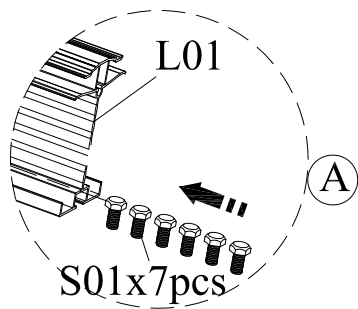

PART	#	mm	Qty.
	L01	2932	1
	S01	M6*12	7
	M01	M6	4
	N01	Ø6*Ø12*1	4



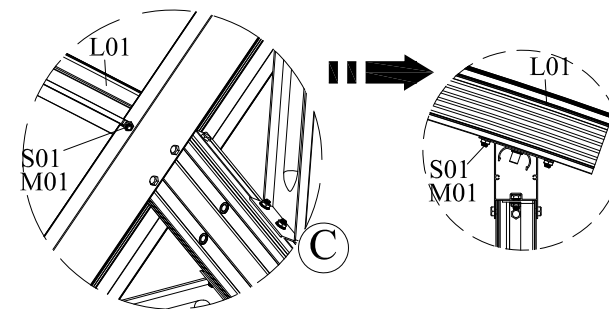
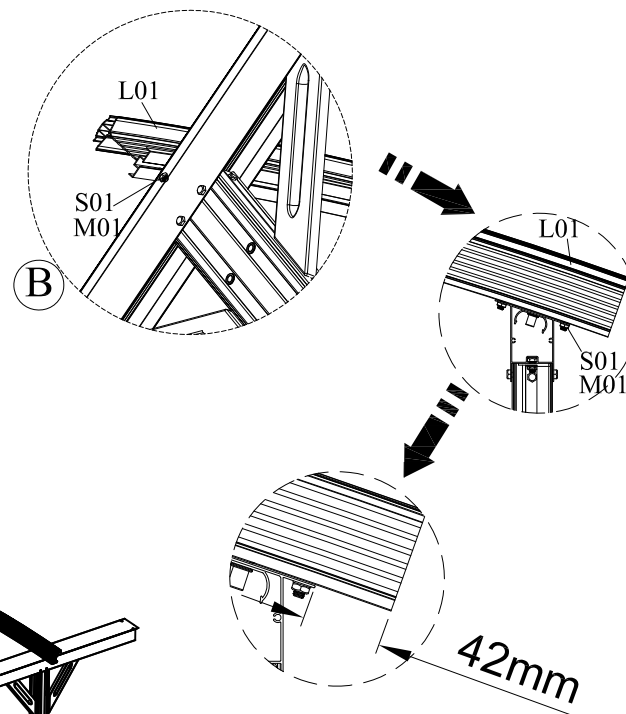
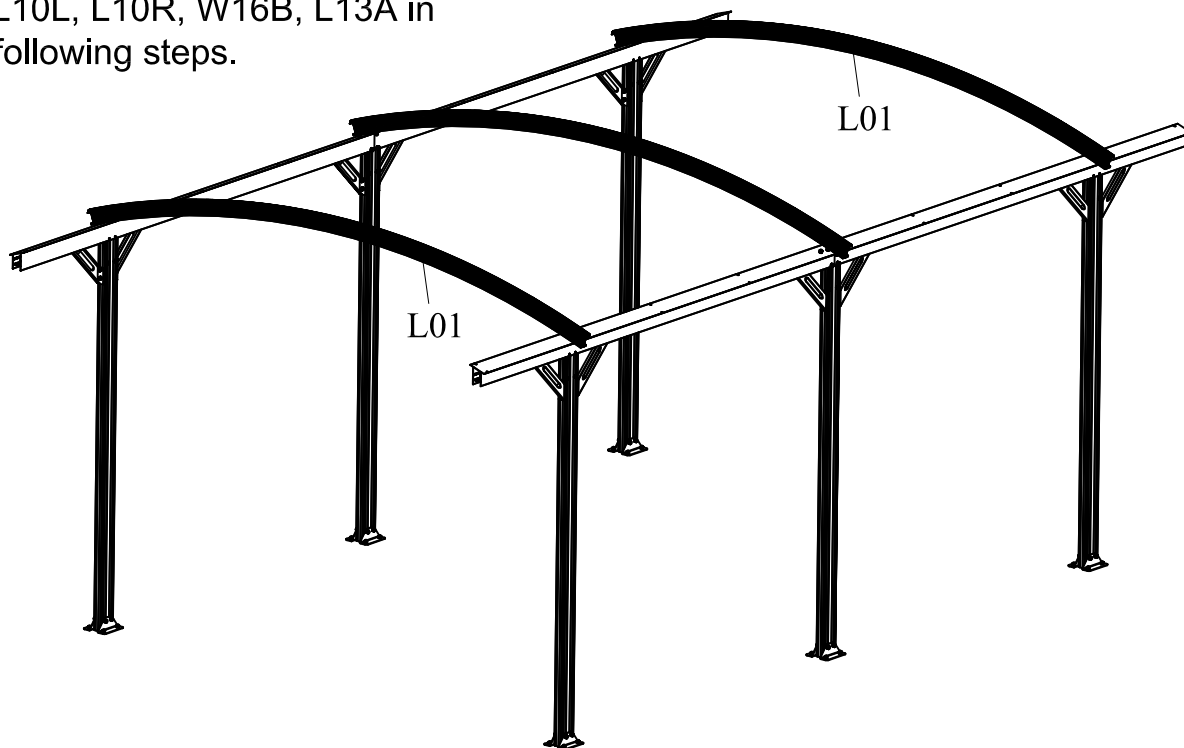

Pre-sliding bolt S01 x 7
before assembling L01, they
will be used for assemble
L10L, L10R, W16B, L13A in
following steps.

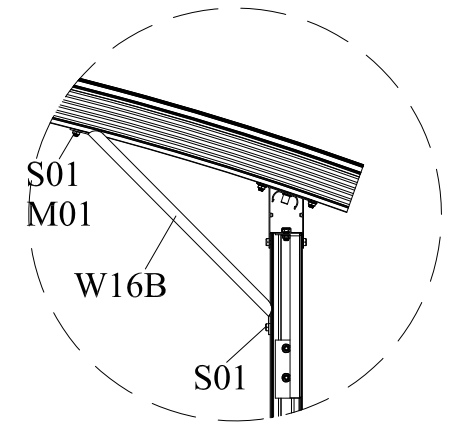
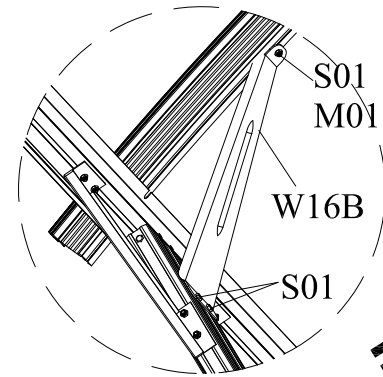
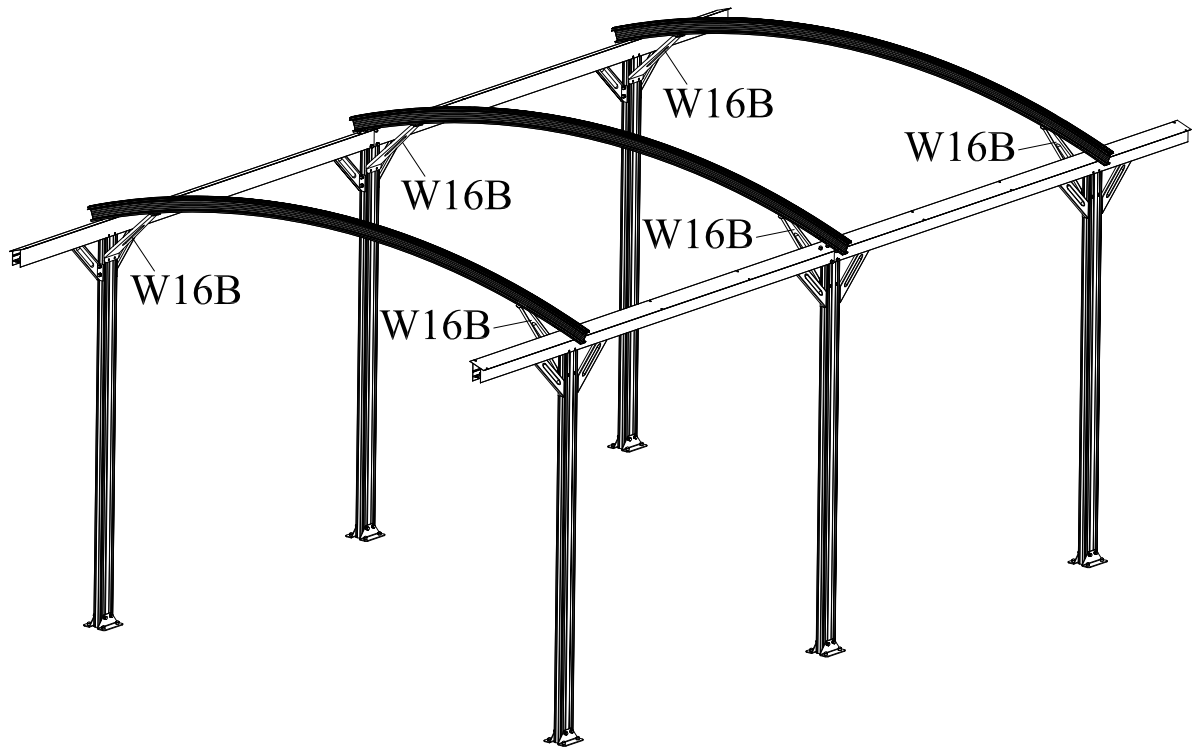

PART	#	mm	Qty.
	L01	2932	2
	S01	M6*12	14
	M01	M6	8



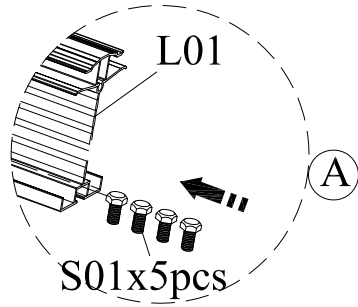

PART	#	mm	Qty.
	W16B	392*104*33	6
	S01	M6*12	12
	M01	M6	6

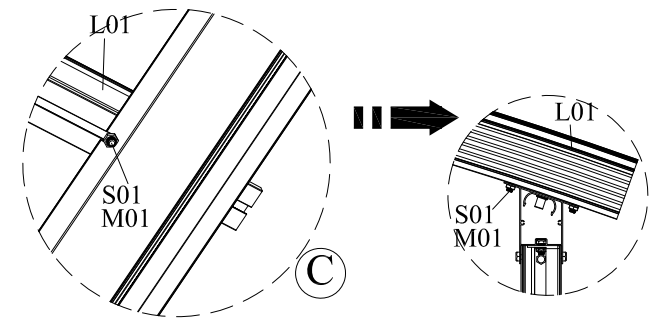
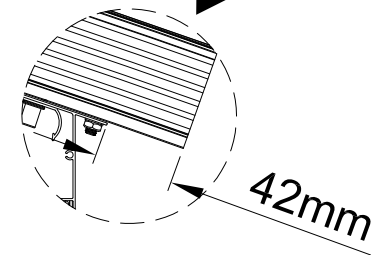
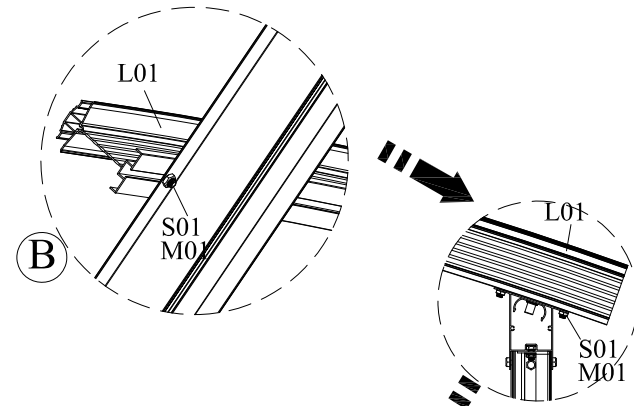
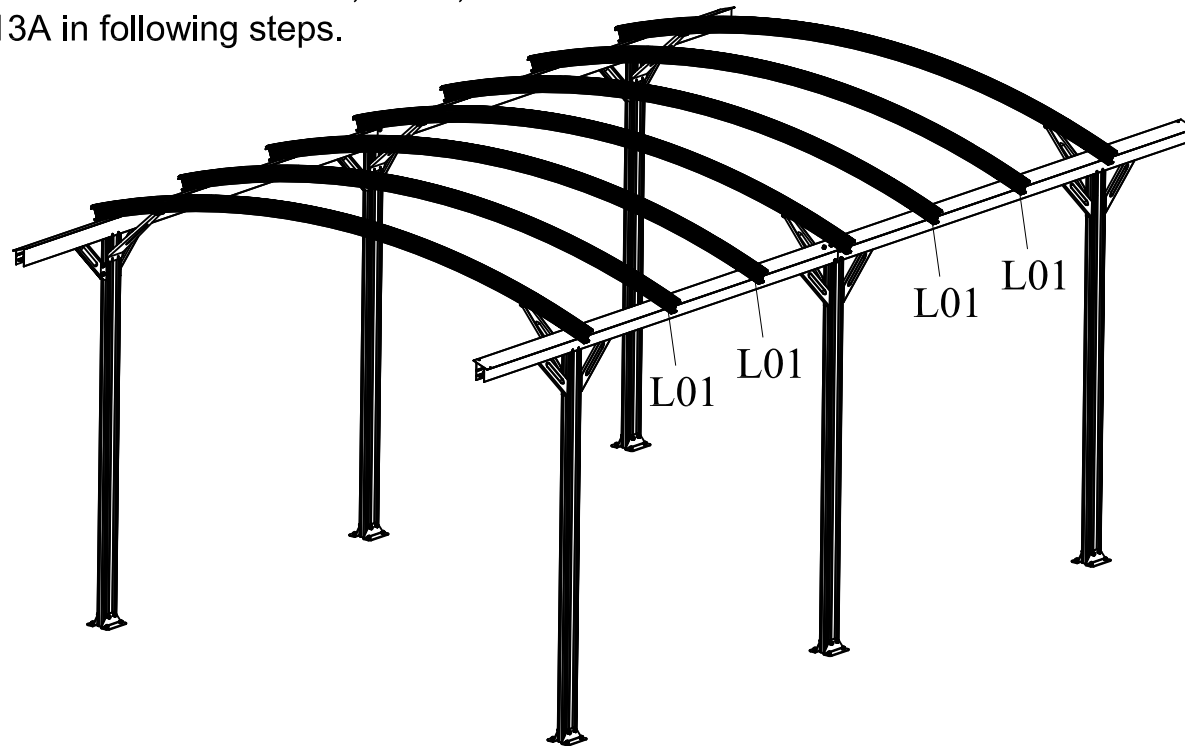

Pre-sliding bolt S01 x 5 before assembling L01, they will be used for assemble L10L, L10R, L13A in following steps.



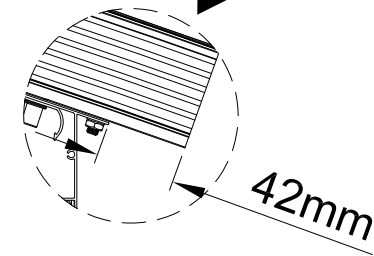
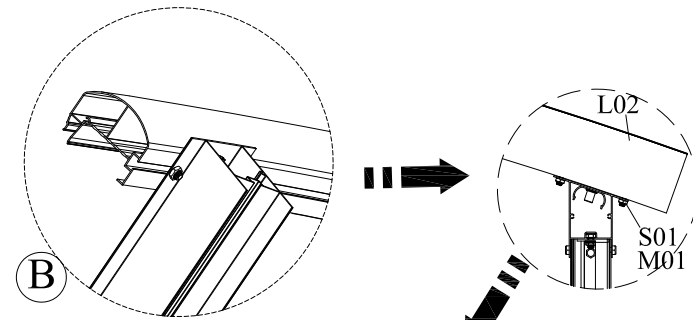
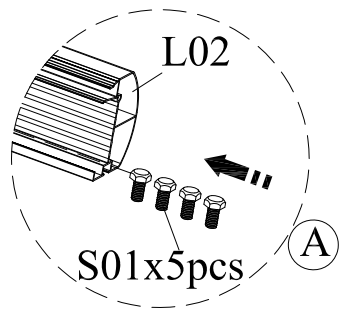

PART	#	mm	Qty.
	L01	2932	4
	S01	M6*12	20
	M01	M6	16



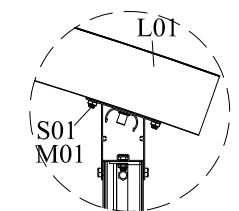
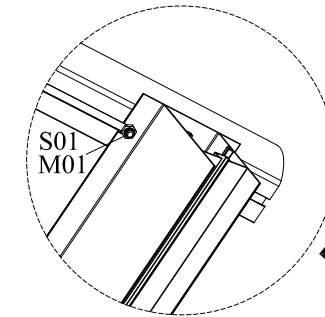
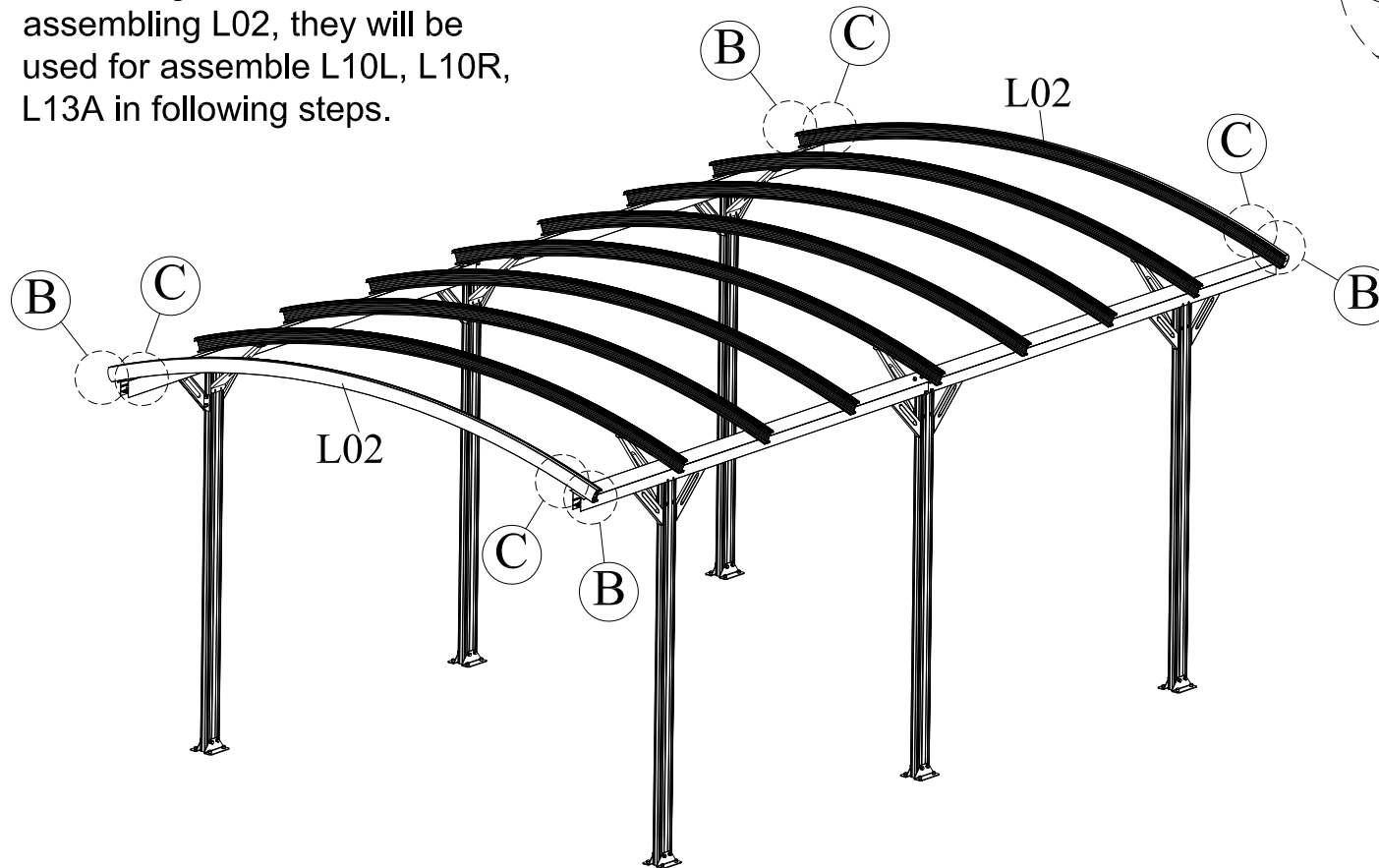



Pre-sliding bolt S01 x 5 before assembling L02, they will be used for assemble L10L, L10R, L13A in following steps.

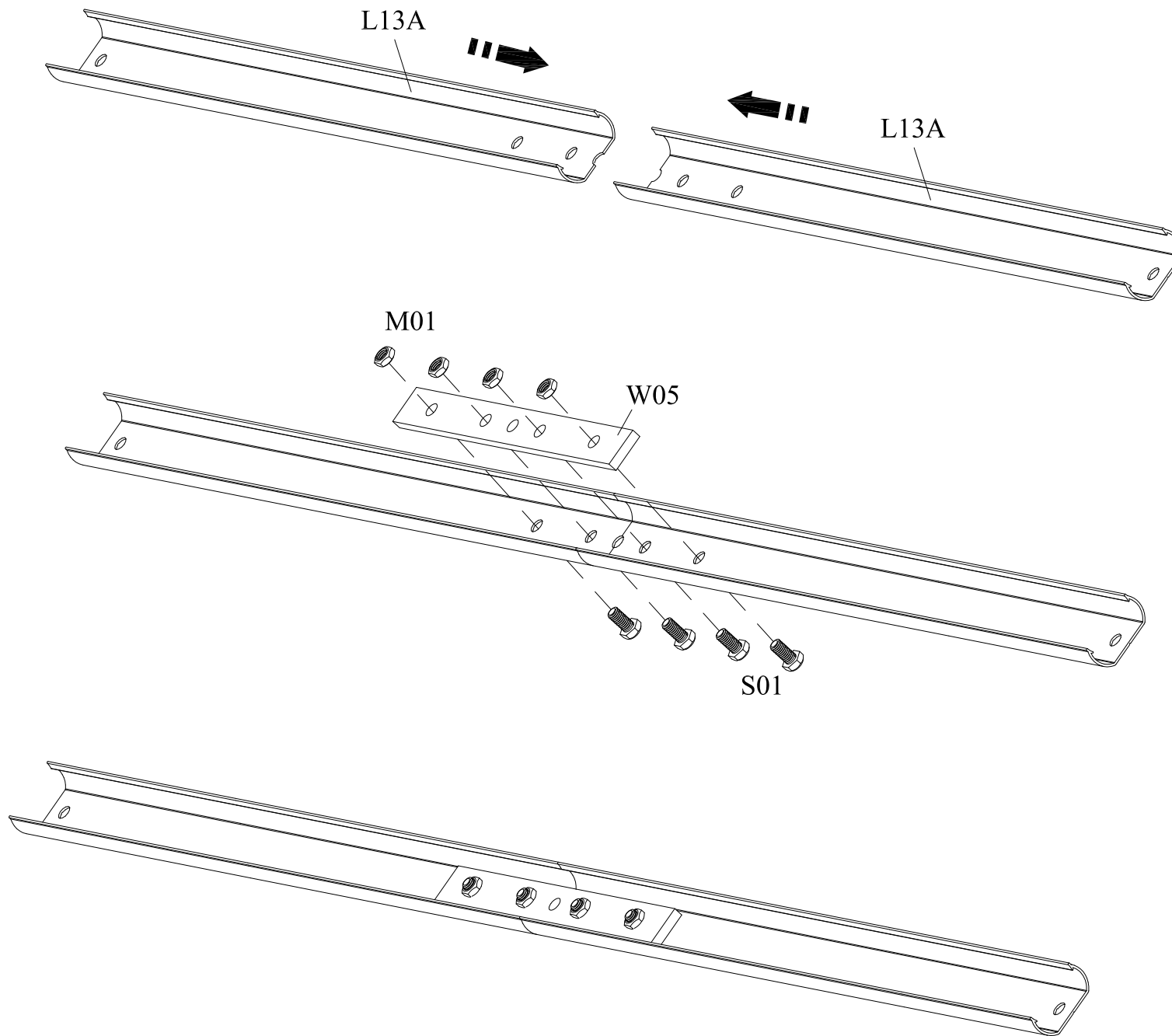





PART	#	mm	Qty.
	L02	2932	2
	S01	M6*12	10
	M01	M6	8

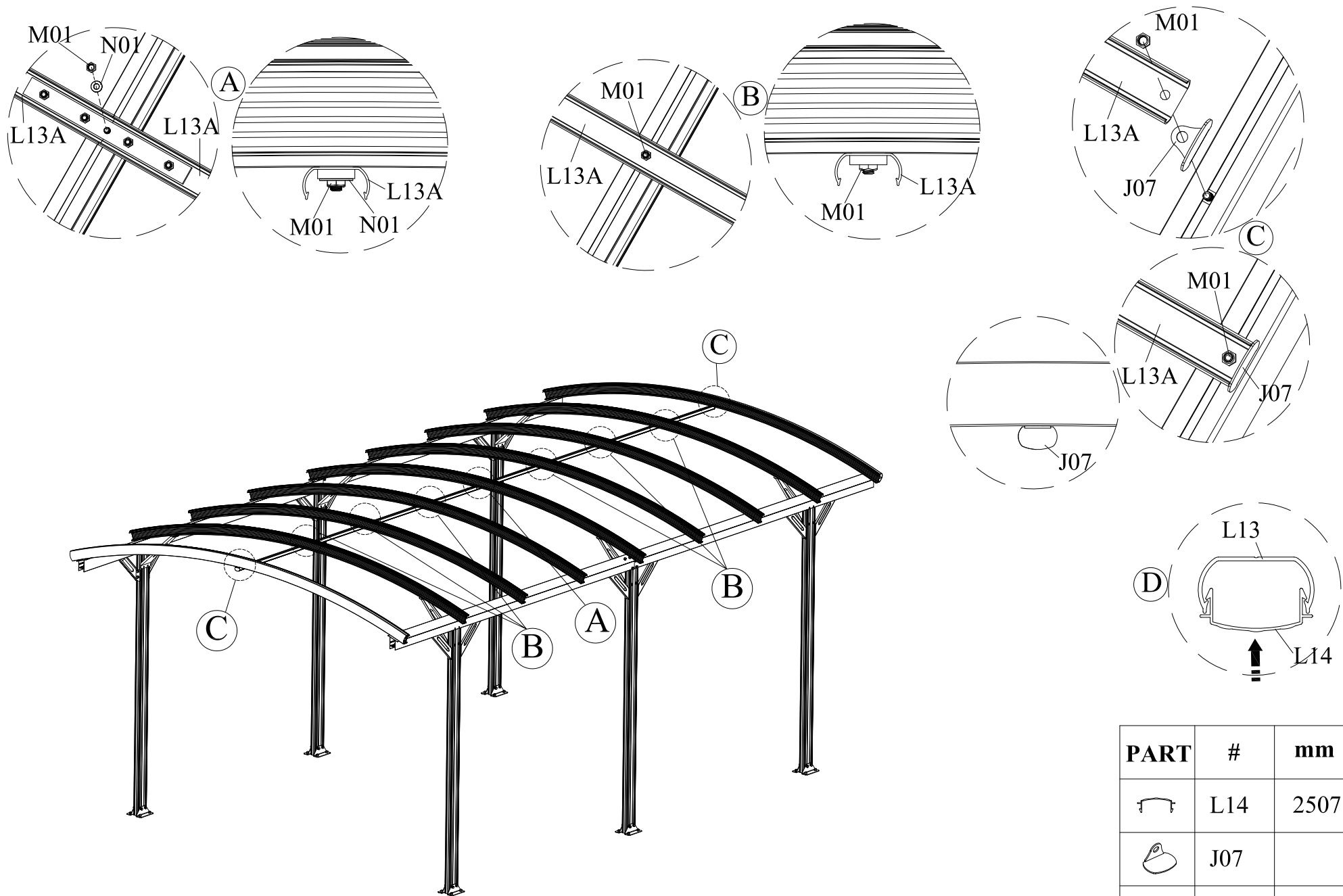

PART	#	mm	Qty.
	L13A	2507	2
	W05	200*20*5	1
	S01	M6*12	4
	M01	M6	4



PART	#	mm	Qty.
	L14	2507	2
	J07		2
	M01	M6	9
	N01	Ø6*Ø12*1	1

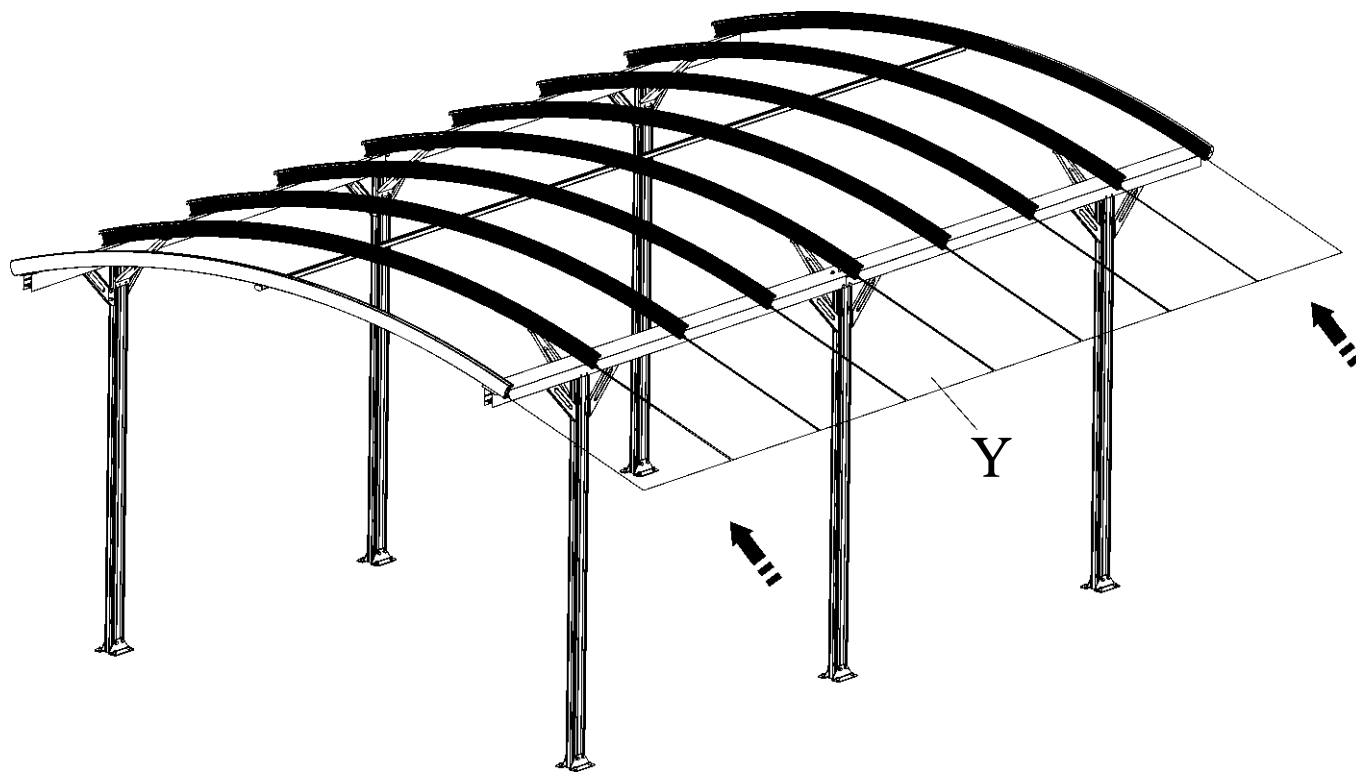

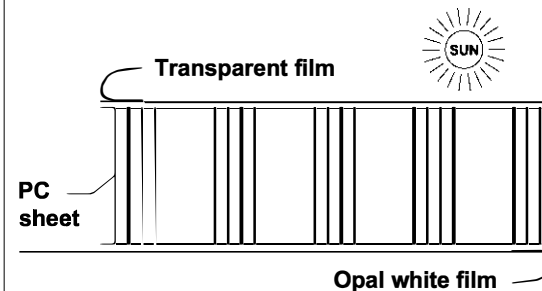

POLYCARBONATE PANEL

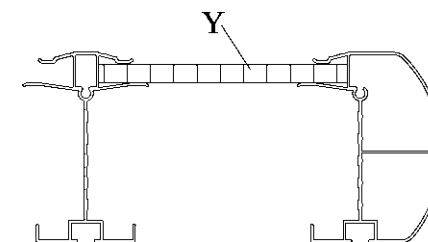

Two sides of PC sheet are covered with thin film, one side's film is transparent, another side's film is opal white. The UV-protected side of PC sheet is covered with transparent film and must face towards the sun.

Please remove protective films from the polycarbonate sheet before positioning them.



PART	#	mm	Qty.
	Y	3000*612	8

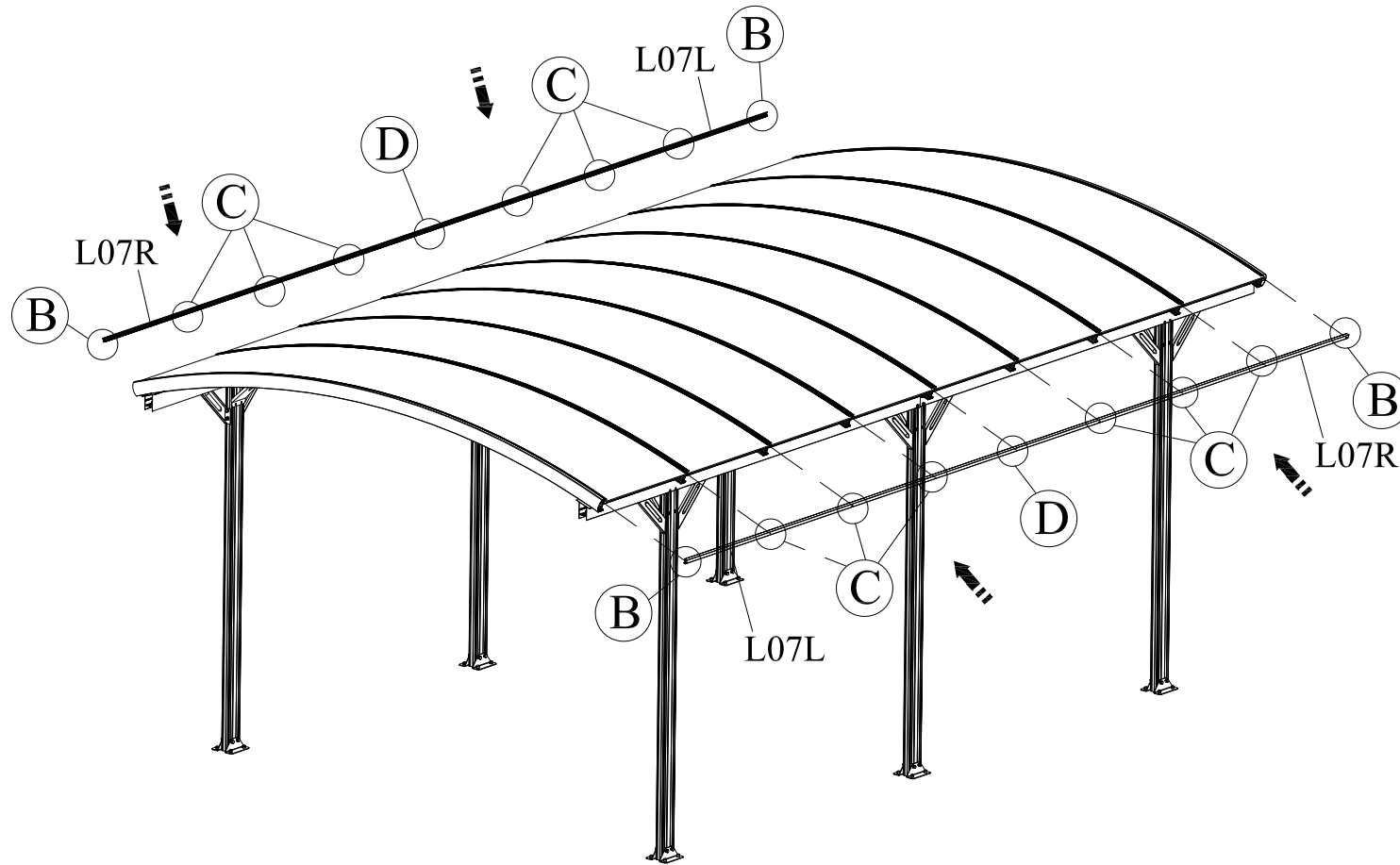
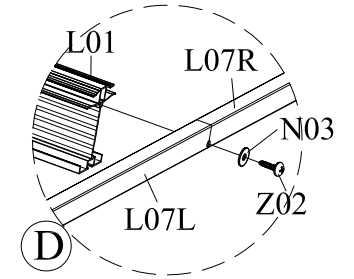
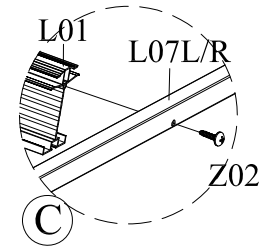
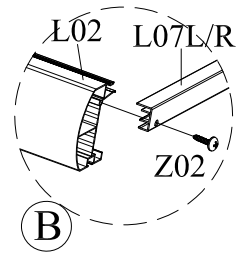
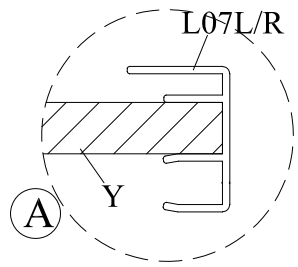

PART	#	mm	Qty.
E	L07L	2507	2
	L07R	2507	2
	Z02	Ø4*16	18
	N03	Ø5*Ø15*1	2

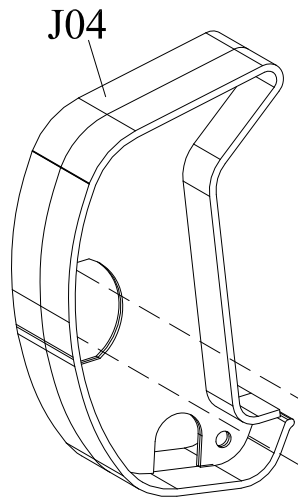

(A)

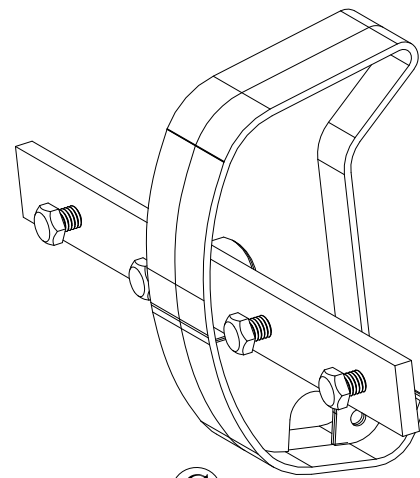

(C)

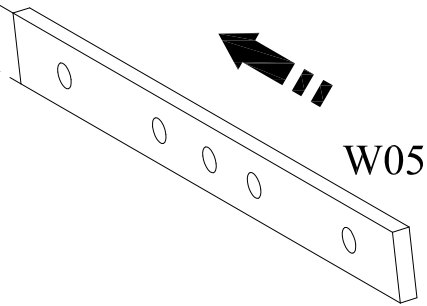



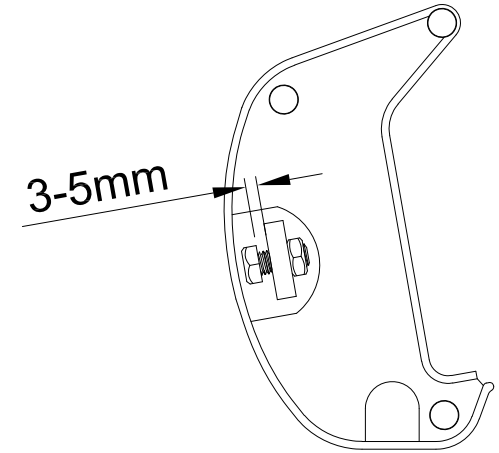

W05

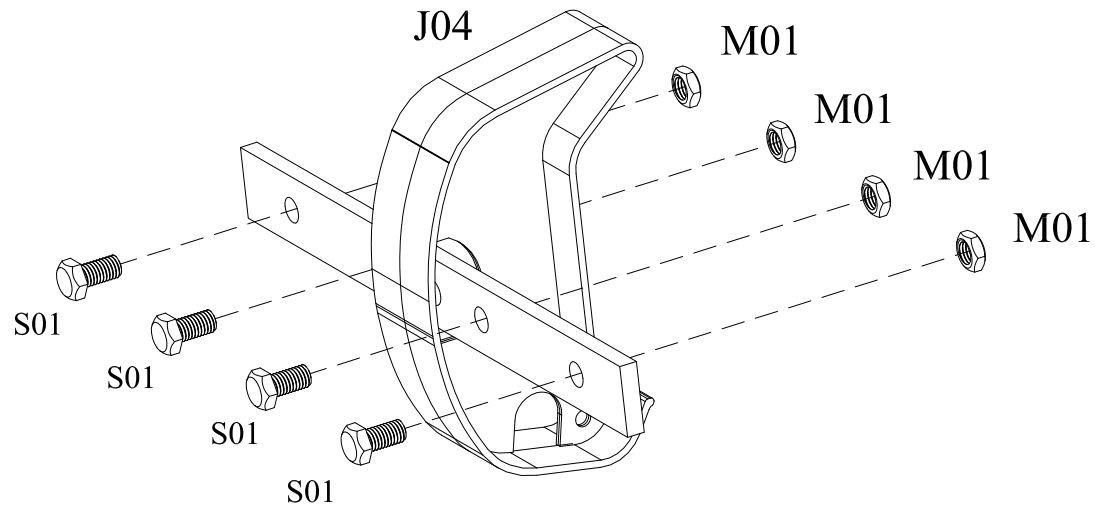



(D)





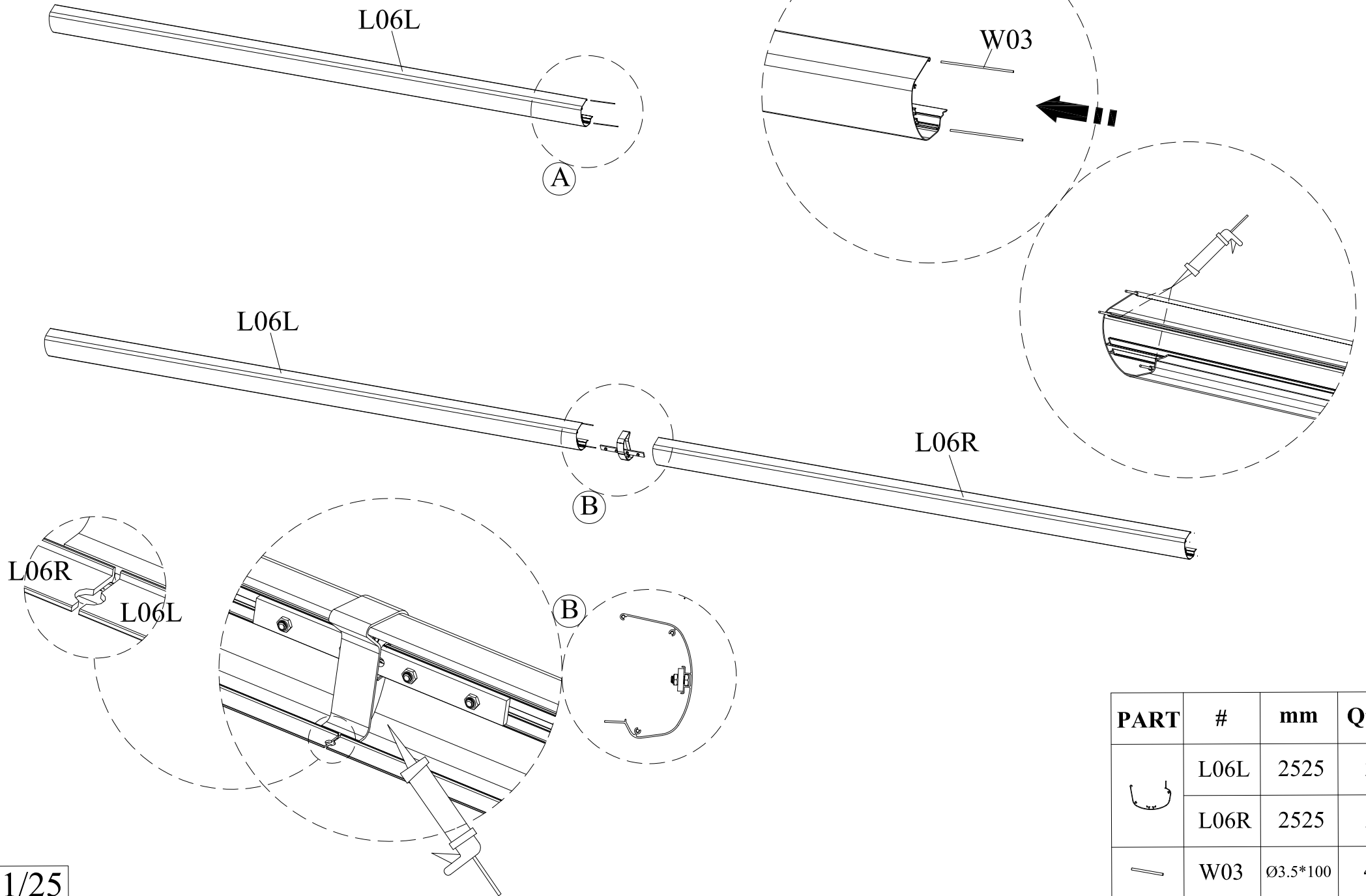

(B)

PART	#	mm	Qty.
	J04		2
	W05	200*20*5	2
	S01	M6*12	8
	M01	M6	8

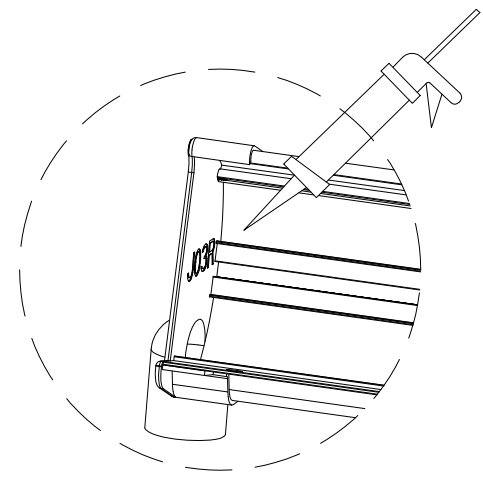
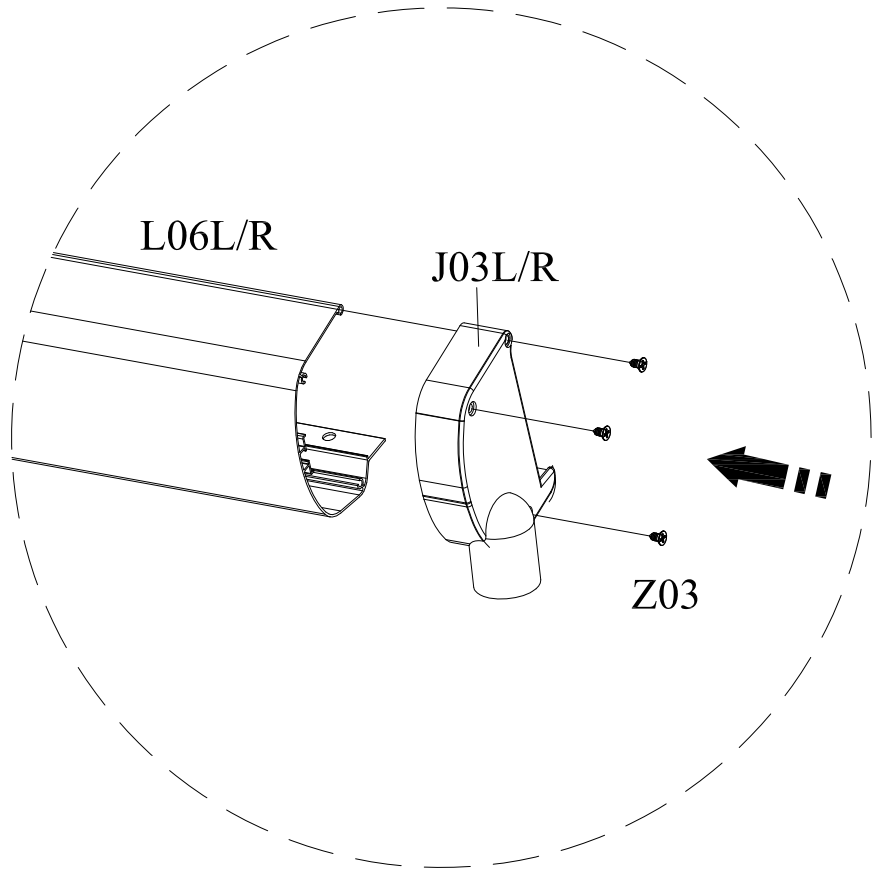
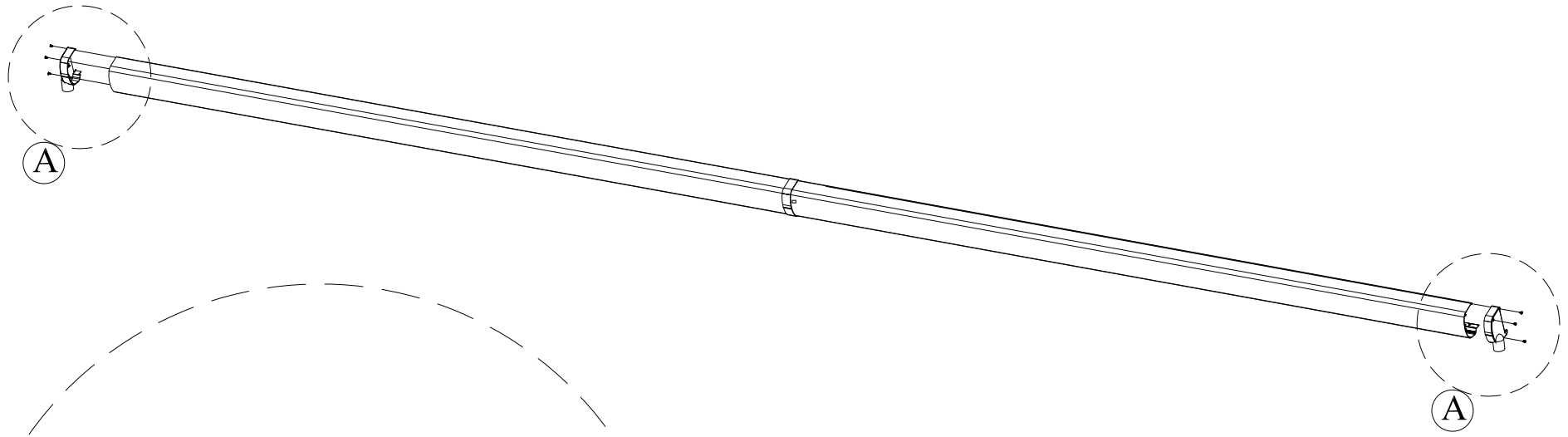



PART	#	mm	Qty.
	L06L	2525	2
	L06R	2525	2
	W03	Ø3.5*100	4



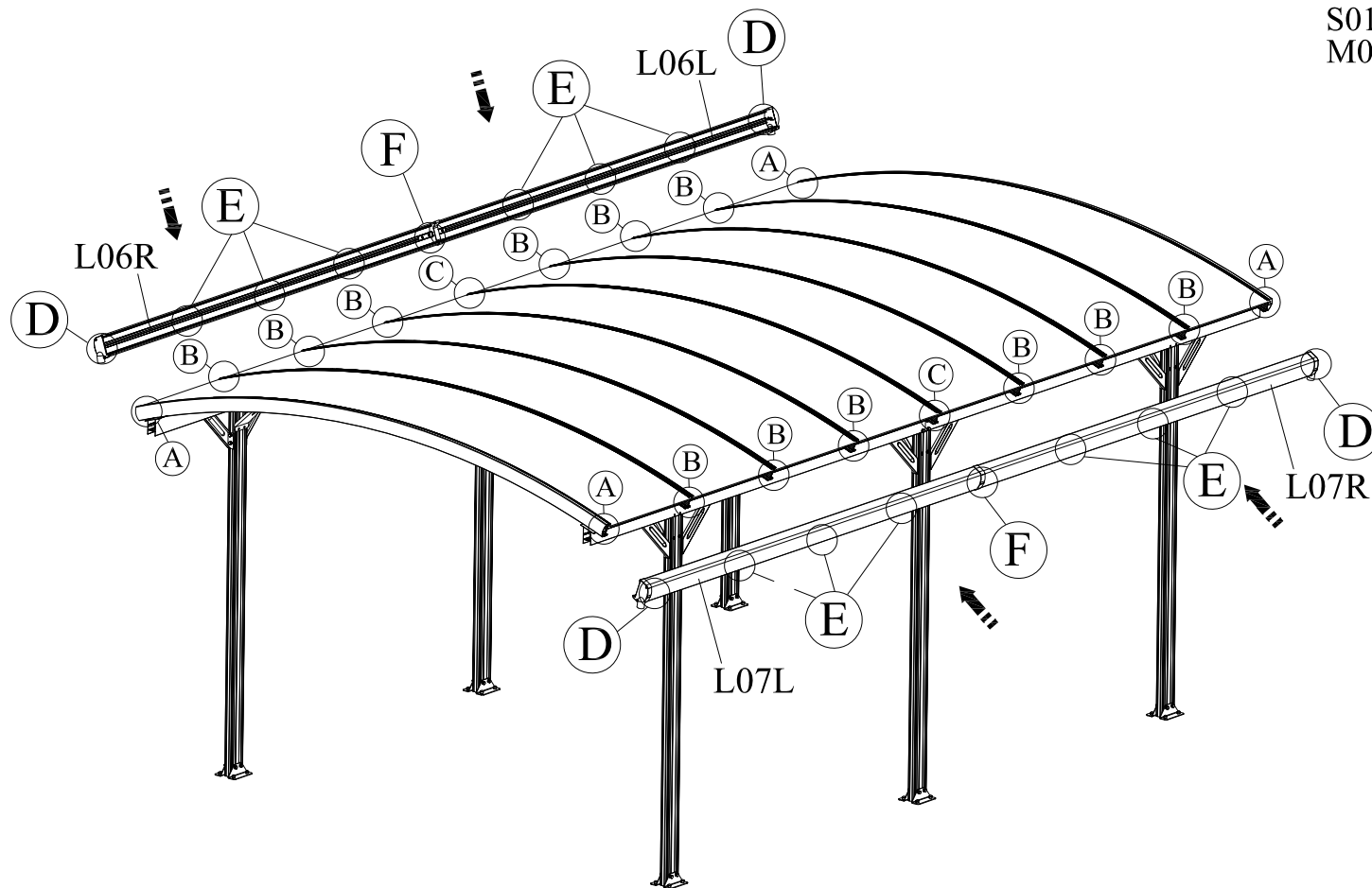
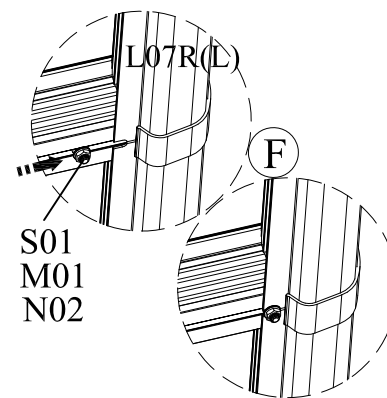
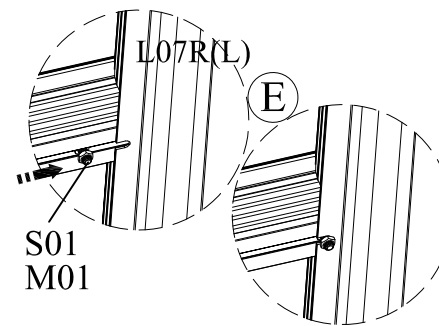
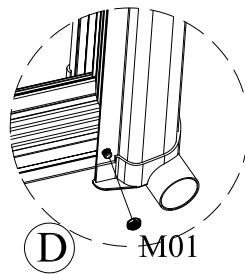
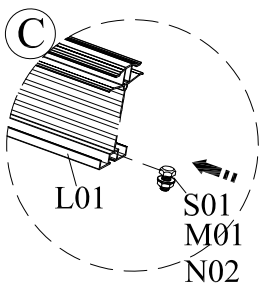
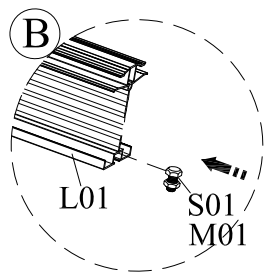
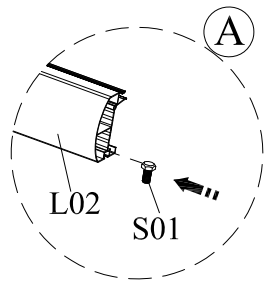

PART	#	mm	Qty.
	J03L		2
	J03R		2
	Z03	Ø4*8	12



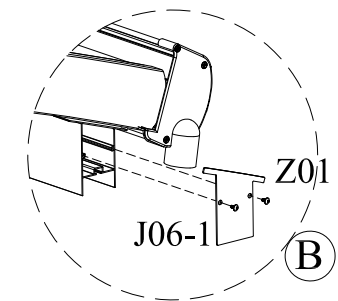
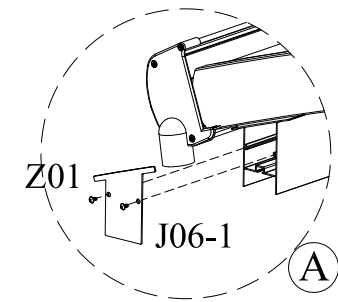
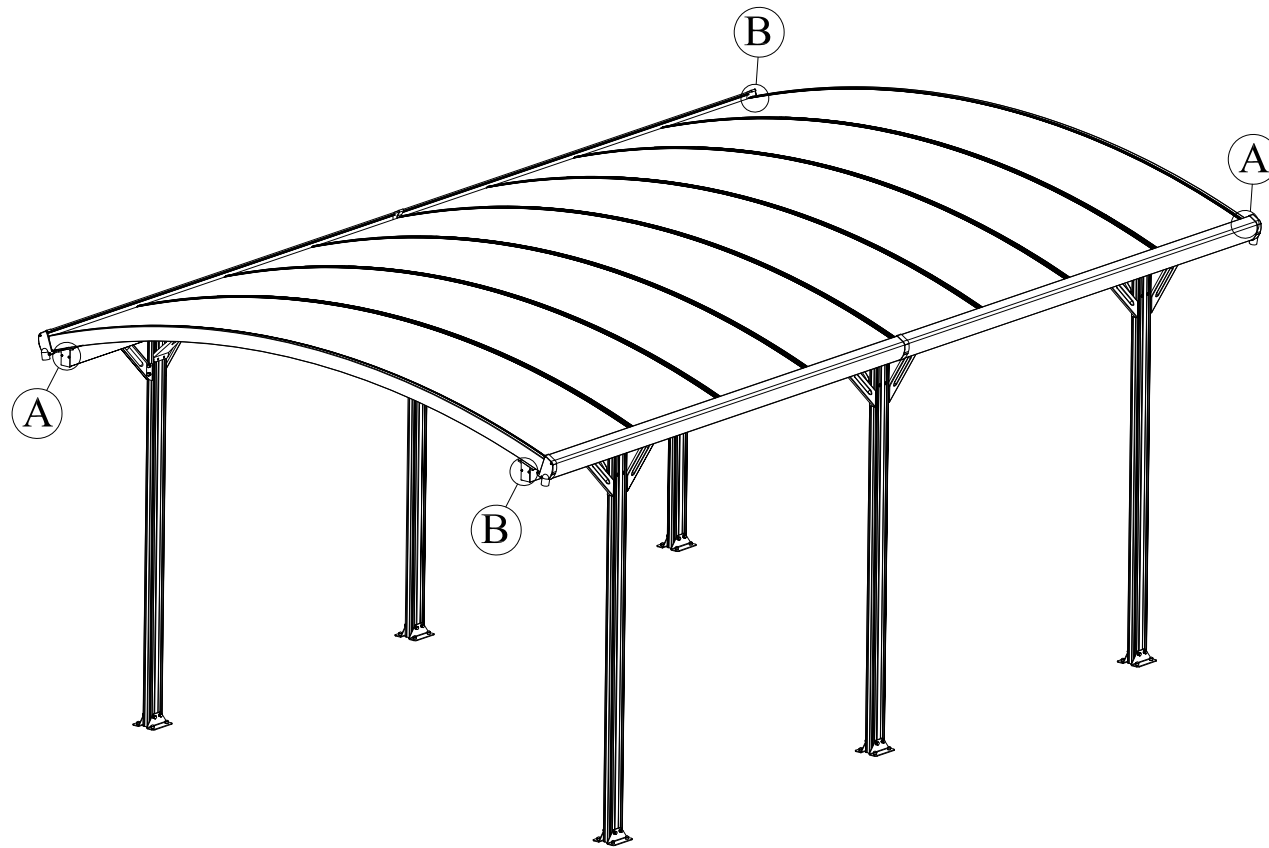

PART	#	mm	Qty.
	S01	M6*12	18
	M01	M6	18
	N02	Ø6*Ø18*1	2

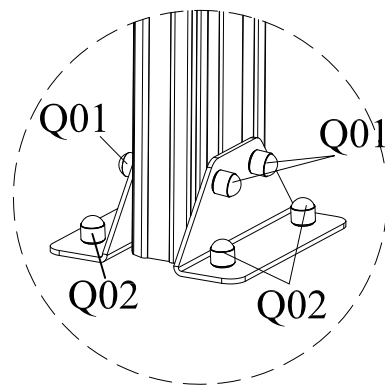
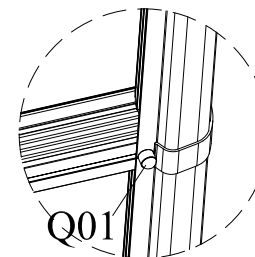
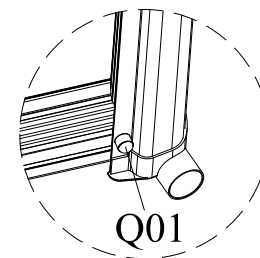
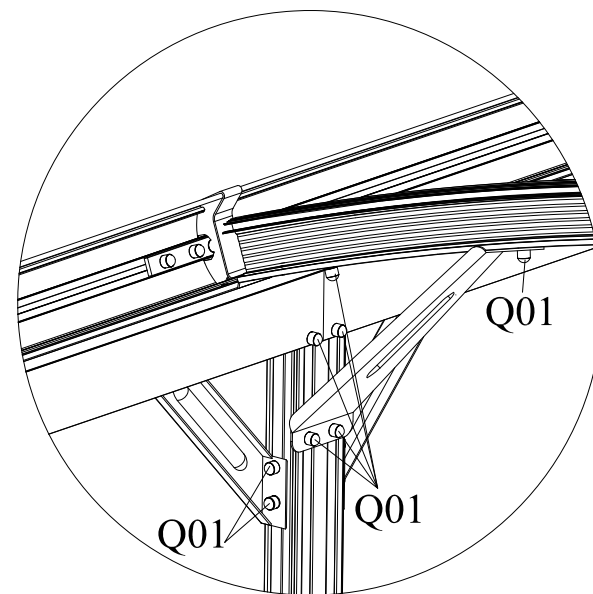
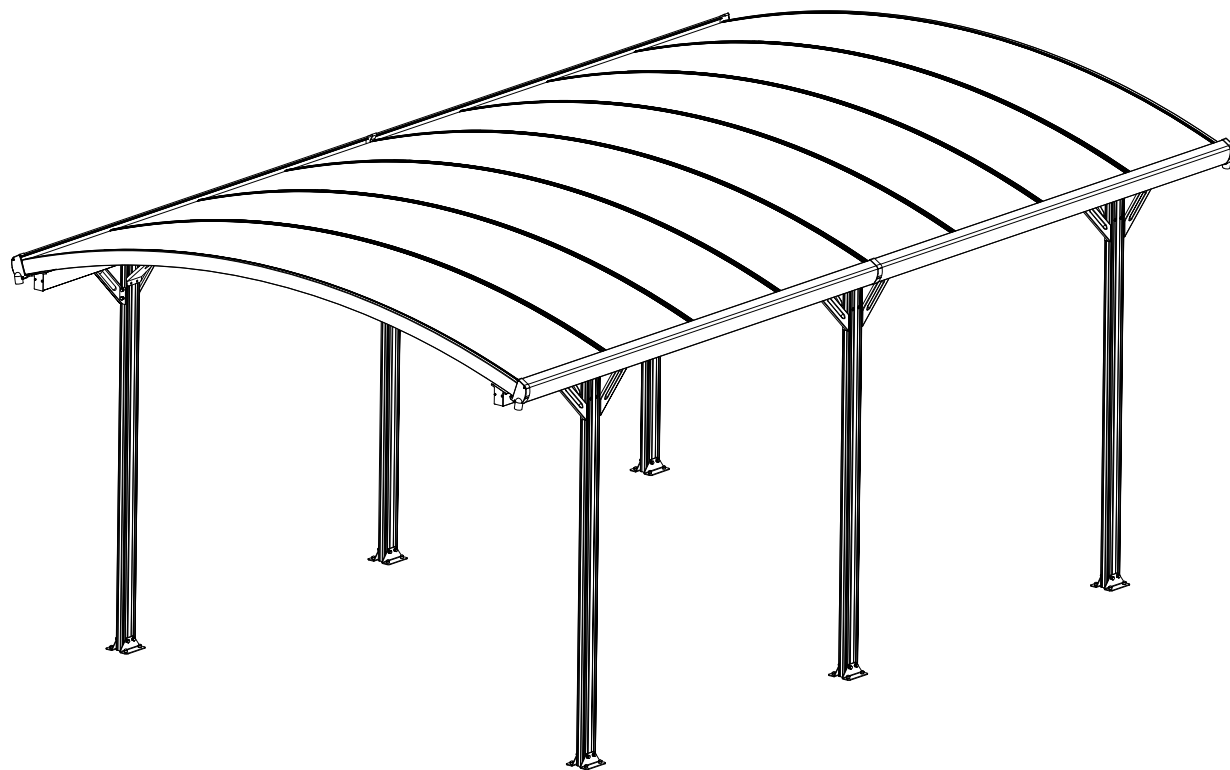

PART	#	mm	Qty.
	J06-1		4
	Z01	Ø4*6	8



PART	#	mm	Qty.
	Q01	M6*10	176
	Q02	M8*14	24

DANCOVER[®]

.com

Contact information

Austria



Belgium



Croatia



Denmark



Estonia



Finland



France



Germany



Ireland



Italy



Latvia



Lithuania



Nederland



Norway



Poland



Portugal



Spain



Sweden



Switzerland



UK



For more information please visit: www.dancovershop.com